

5/16 x 7/16 x 2 Brass, 2 Req.

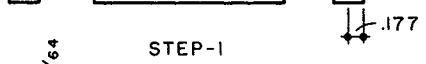

STEP-1

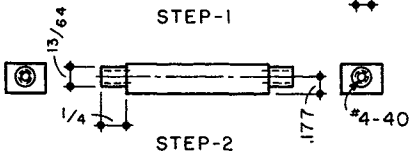

STEP-2

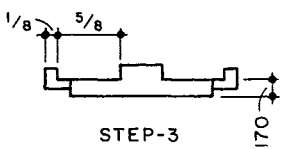

STEP-3

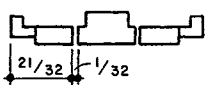

STEP-4

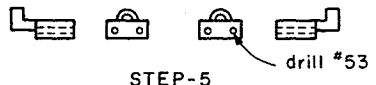

STEP-5

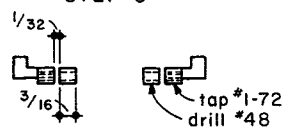

STEP-6

STEP-6A

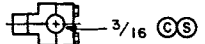

STEP-7

PISTON ROD BEARING
4 Required

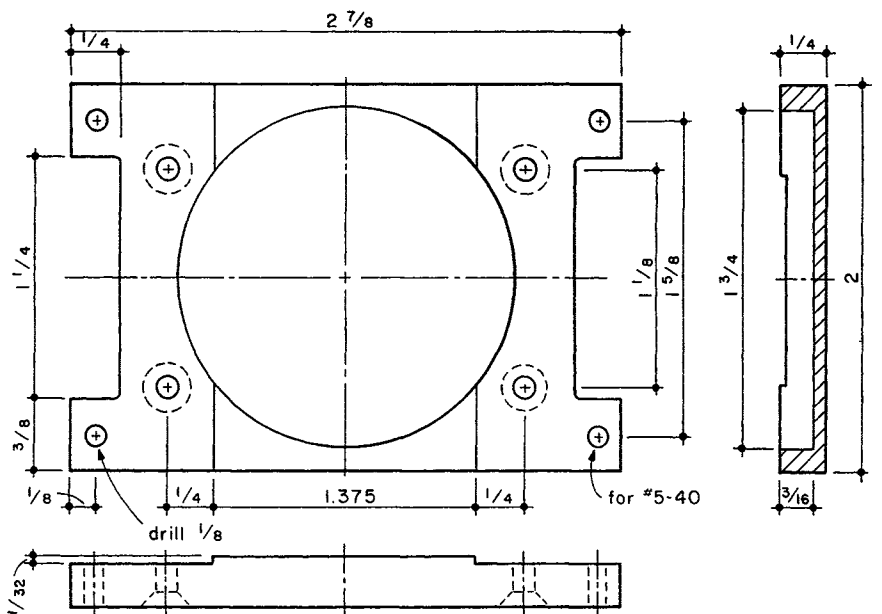

FOOT
Aluminum

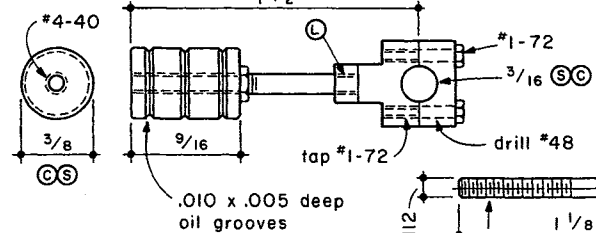
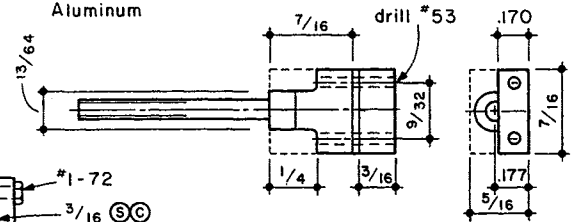

PISTON & ROD
Brass, 4 Required
See 7 Steps

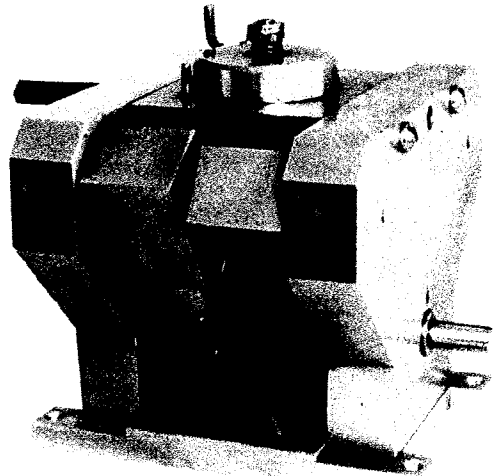
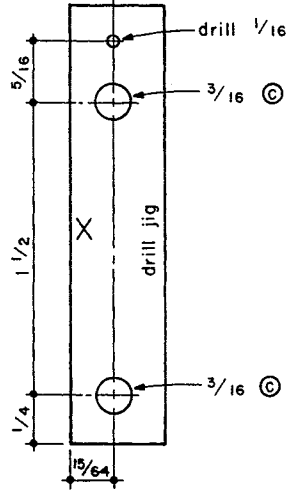
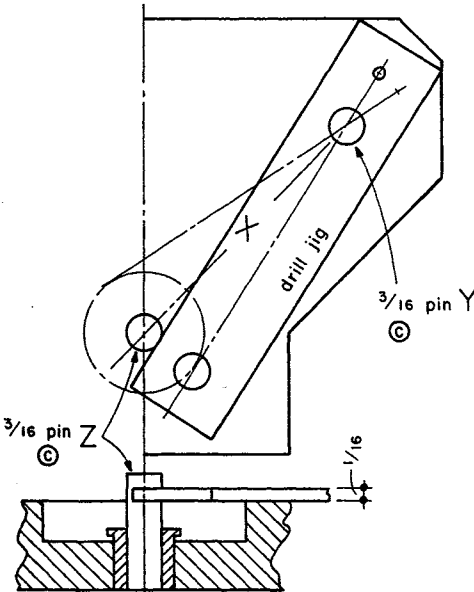

27

V4 Wobbler

This engine was inspired by Jan Gunnarson's V4. I would say Jan's engine using cast iron, steel and bronze would make a more durable engine and, under steam, can take a lot more than this aluminum engine. I offer my apologies to Jan. This is just another approach to his basic design.

Scribe the "V" outline and all the centerlines on the 2-1/4" x 3-1/8" **END PLATES**. Chuck in the 4-jaw and center for the Crankshaft Bearing and 1-1/16" recess. Make **BUSHINGS** and press in flush with the back side so the Plates will lie flat on the drill press for other operations. Oilite was used for the Crankshaft Bearings. Bushings were chosen for the Cylinder pivots. Do not break into the steam passage in Section G.

Make the **DRILL JIG**. Insert a short-close fitting 3/16" pin **Y** in the pivot hole and place the Jig over it with **X** side against another short 3/16" pin **Z** in the Crankshaft hole as shown. Drill the 1/16" steam hole only 1/64" to 1/32" deep in the Plate. Turn the jig over and drill the other hole. These holes are shallow now for locating purposes only. If drilled deeper they might deflect the crosshole drill.

Pick up and transfer the centerline of these holes to the edges of the Plate. The crossholes require some careful study and layout. Note they are at 3/32", 7/32" and 11/32" from the face and are drilled to different depths. These were drilled 1/16" but they could be 5/64" for better steam flow. Lay out and drill the four holes in the top edge at 1/4" and 7/16" spacing. They intersect the cross holes. Now do the same with four holes from the face at 1/4" and 7/16", intersecting the vertical holes you just made. Go back to the shallow 1/16" holes made with the jig and drill them into the crossholes.

Drill the screw holes for the Valve Plate and drill and tap for the foot screws. Cut these **END PLATES** to the "V" shape. Press the Bushings in against their shoulders and drill the three oil holes starting with a 1/16"

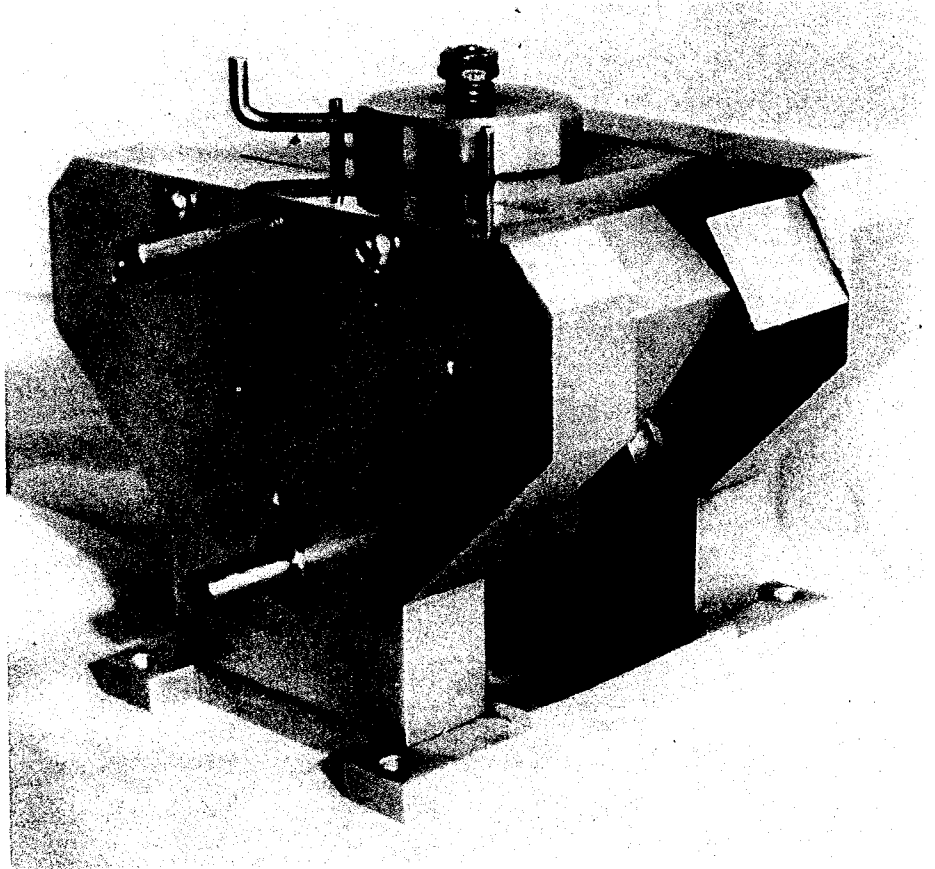

end mill. Don't break into the crosshole shown at section D.

Clean out all chips. The steam passages are now done except for plugging. The stock for plugging should be about .002" larger than the drilled holes. File a slight taper on the plug that will allow the plug to enter the hole about 1/32". Apply a tiny dab of Loctite and drive in until firm; cut off and dress flush. Do not drive deep enough to close off a steam passage. These passages do not have streamline flow for the steam but the steam does get to the Cylinders.

The holes in the **VALVE PLATE** require careful layout and machining that must match the above End Plates and the Valve, so no steam passages will be partially closed off at assembly. Insert a close-fitting pin in each End Plate center steam hole and corresponding hole in the Valve Plate. Line up and clamp the two End Plates

and Valve Plate together. Insert a piece of 3/16" drill rod through the shaft holes. It should rotate freely. Spot the 4-40 holes in the Valve Plate. Remove and complete drilling and tapping.

After completing the Valve Plate and Valve, insert the 5-40 stud. Make a close-fitting pin about 5/32" long and insert it in one of the four Valve holes in the Plate and lower the Valve over it, engaging one end of the valve slot and clamp. Spot a 1/16" hole at **A** with the drill just touching the lever. Lift the Valve and repeat for the other Valve position at **B**.

Make the **FOOT**. The important dimension is across the shoulders. It should match the Valve Plate.

The **CYLINDERS** start with four accurate pieces 1/2" x 3/4" x 1-5/16". Lay out and center punch for the bore, Pivot and Spring hole. Use the four-jaw chuck and center up and

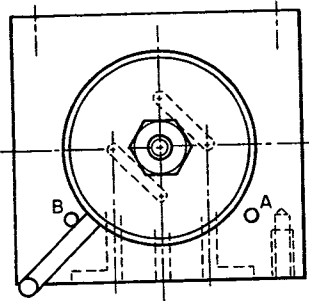

- ⓐ close fit
- ⓑ smooth
- ⓒ press fit
- ⓓ "loctite"
- ⓔ flat

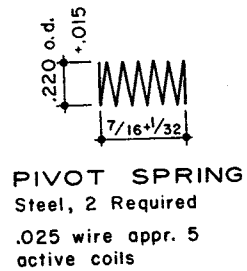
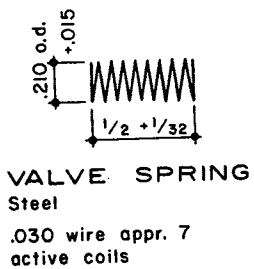
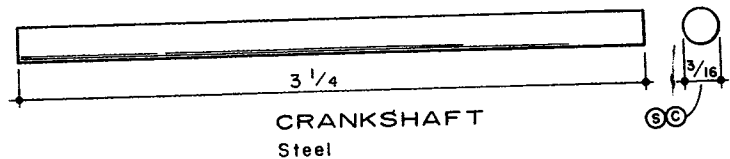
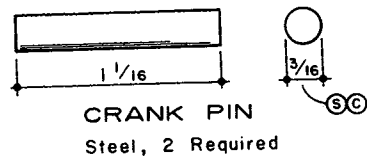
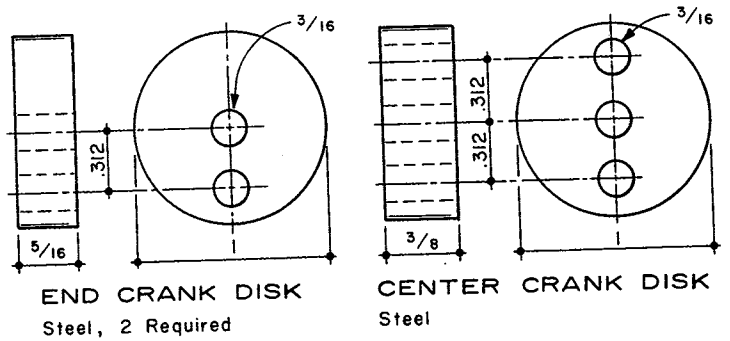
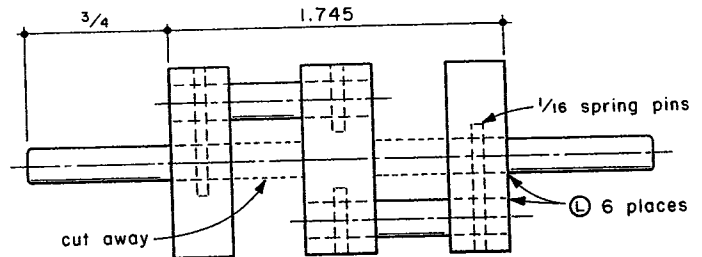
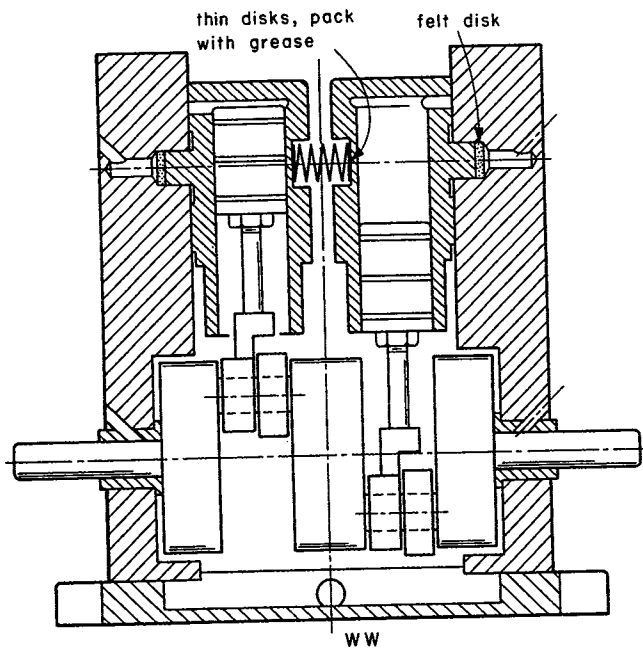
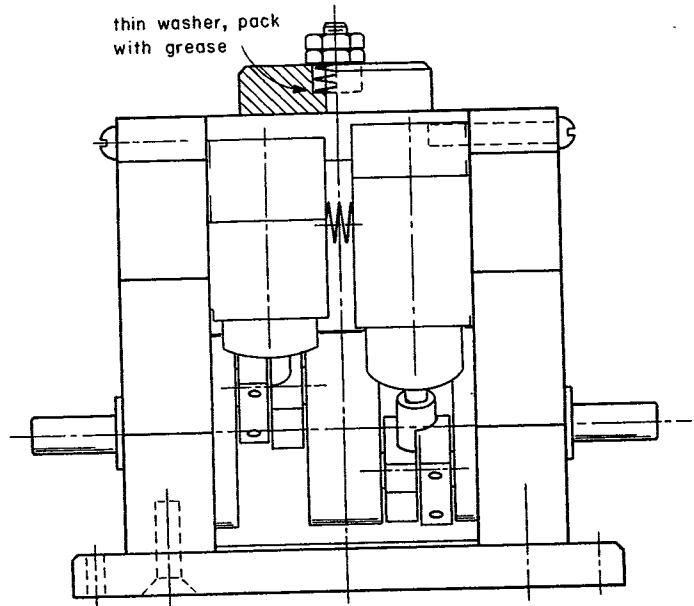
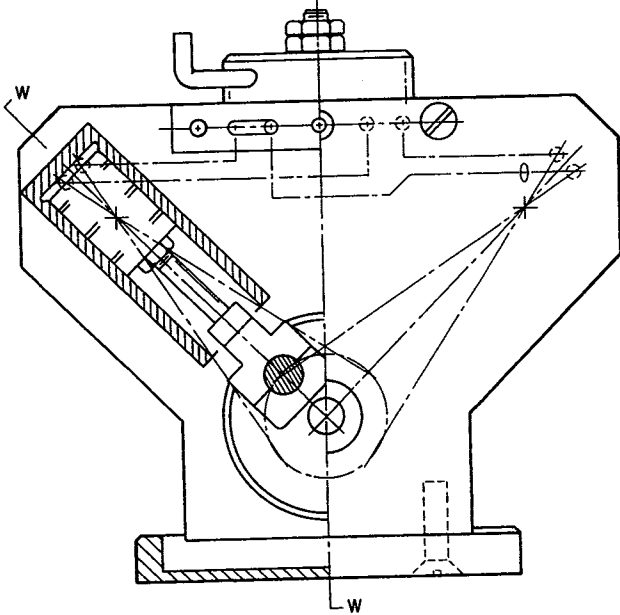

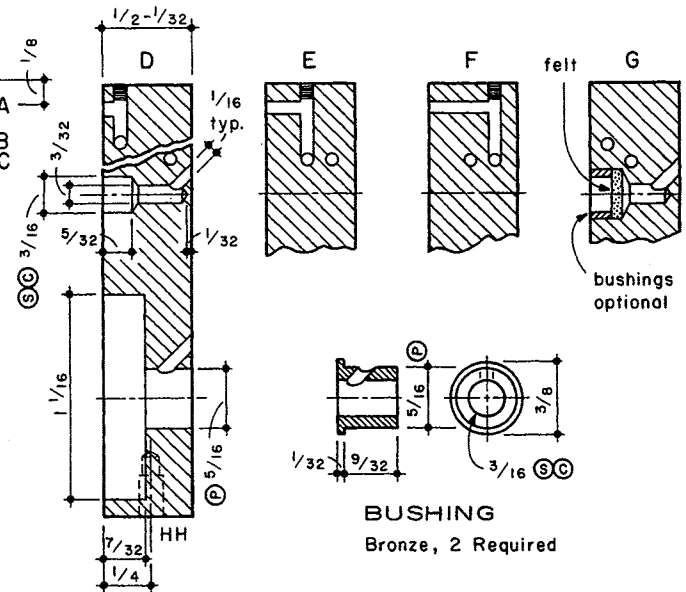
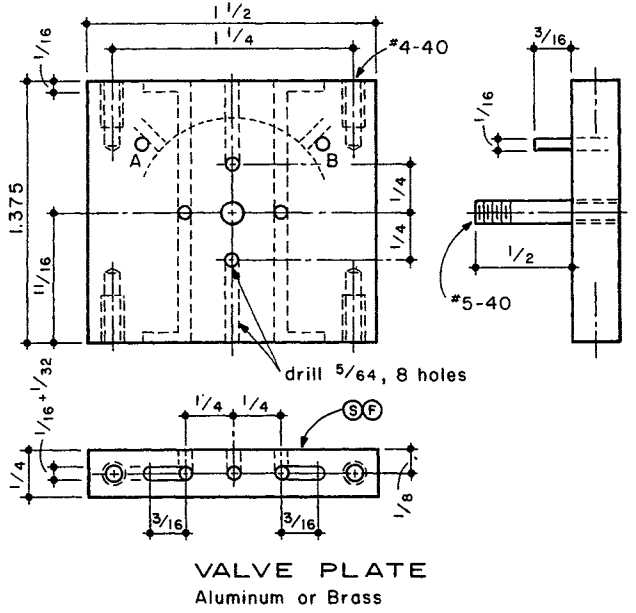
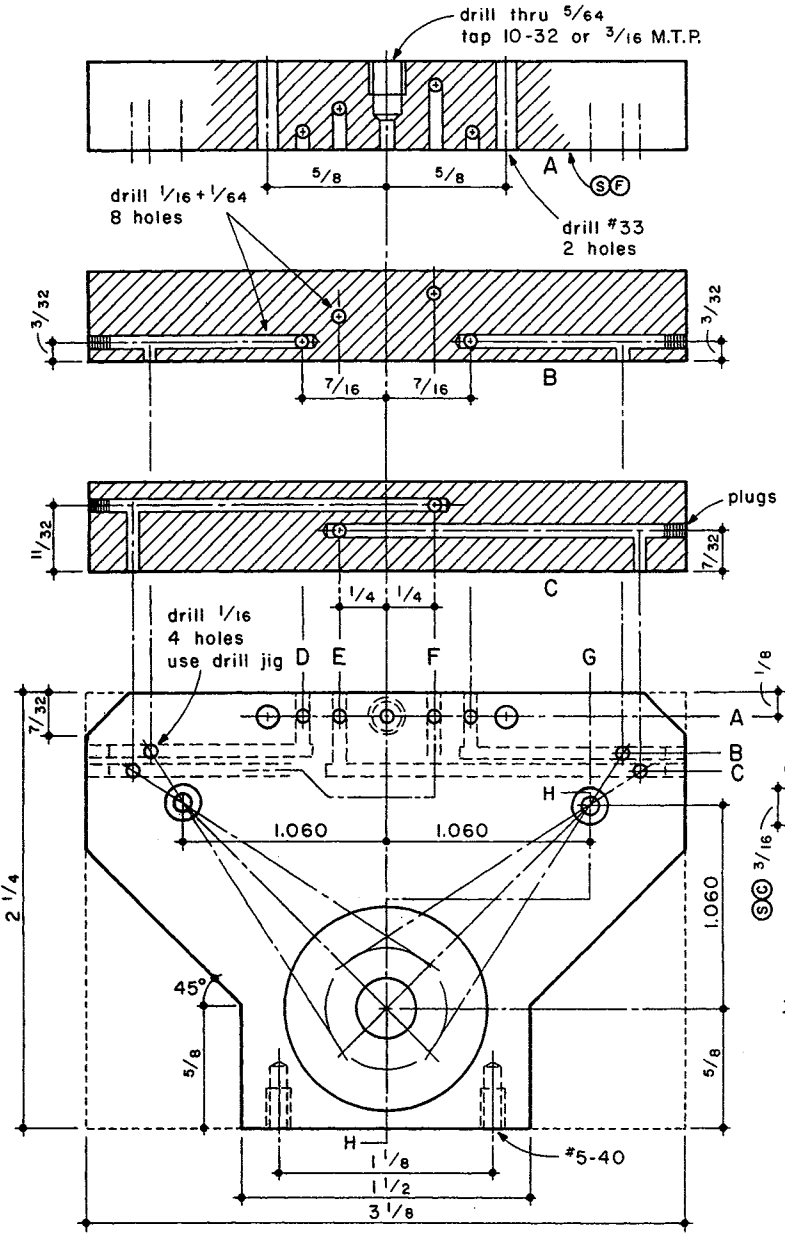
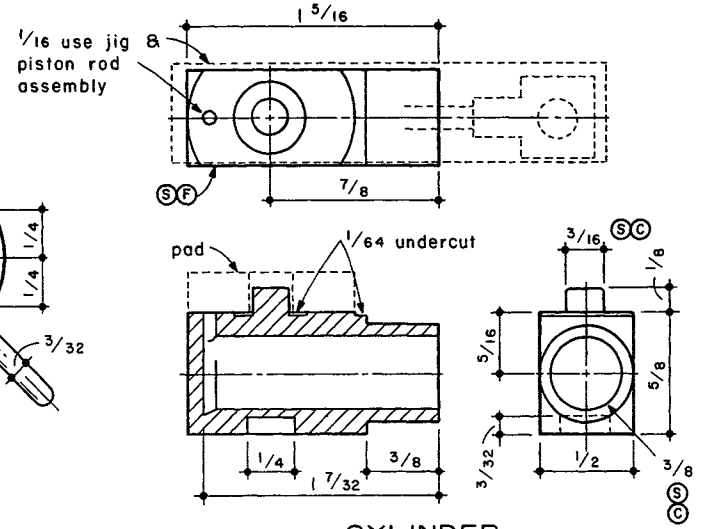
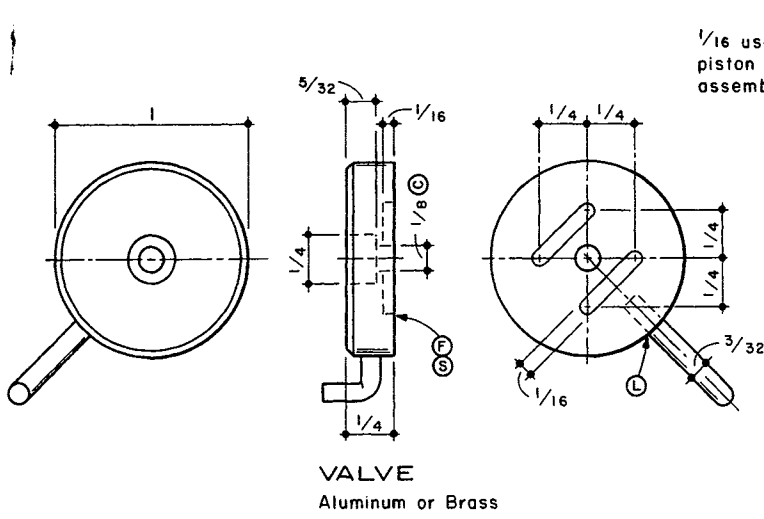

turn the spring recesses. Turn over in the chuck and turn the pivot side of the Cylinder. Use an indicator or parallels to square up in the chuck. Make a chucking pad about 3/16" x 1/2" x 7/8" with a 1/4" hole in the center. Cut a piece of thin cardboard to match with a 1/4" hole. Mount the Cylinder in the 4-jaw with these two pieces protecting the finished Valve face. Center, using a center test indicator and make the 3/8" bore. Back up the boring tool at the bottom of the cut to give the reamer some runout clearance. Turn the 1/2" diameter back 3/8". Drill the steam hole later.

Turn the **PISTONS** and, while still in the lathe, tap the 4-40 hole. Use the Cylinders as gauges and keep each Piston with its own Cylinder from now on. Make the 1-1/8" **ROD** also, threading in the lathe.

The **CONNECTING ROD BEARINGS** are made from two pieces of 5/16" x 7/16" x 2" stock. Apply layout dye over about 3/4" of both ends. Lay out the rod center .177" from one face as in **Step 1**. Chuck, turn and tap both ends as in **Step 2** and then make the 5/8" cut down to .170" thickness as in **Step 3**. The purpose of the .170" and .177" dimensions is to guarantee clearance at the Crank Pin as seen on the assembly drawing. The Bearings should float on the Crank Pin and not touch each other or the Crank Disks, a condition which could tilt a Cylinder off its seat. In **Step 4**, use a 1/32" slitting saw and cut at 21/32". Drill the two holes in each piece in **Step 5**. Again, using the 1/32" saw, cut at 3/16" in **Step 6**. Drill and tap **Step 6A**. Assemble with #1-72 screws, center punch and bore 3/16" for the Crank Pin in **Step 7**.

Now is a good time to make tiny marks on the Caps and Bearings so each Cap can be brought back to its own Bearing to the position at which it was machined.

Insert a Piston in its Cylinder and place the drill jig over the Pivot and insert a short, close-fitting pin through the jig and Connecting Rod hole. Drill the 1/16" steam port.

The **CRANKSHAFT** is made the way Jan laid it out. Turn, bore and ream all three Disks. Drill and ream for the Crank Pins using the 3-jaw chuck on an indexing fixture. Chuck a piece of 3/16" drill rod in the spindle and bring the Disk on center so the rod will freely enter the center bore. "Zero" the collar and feed in .312". Drill and ream at this position for all three Disks. For the center Disk, ro-

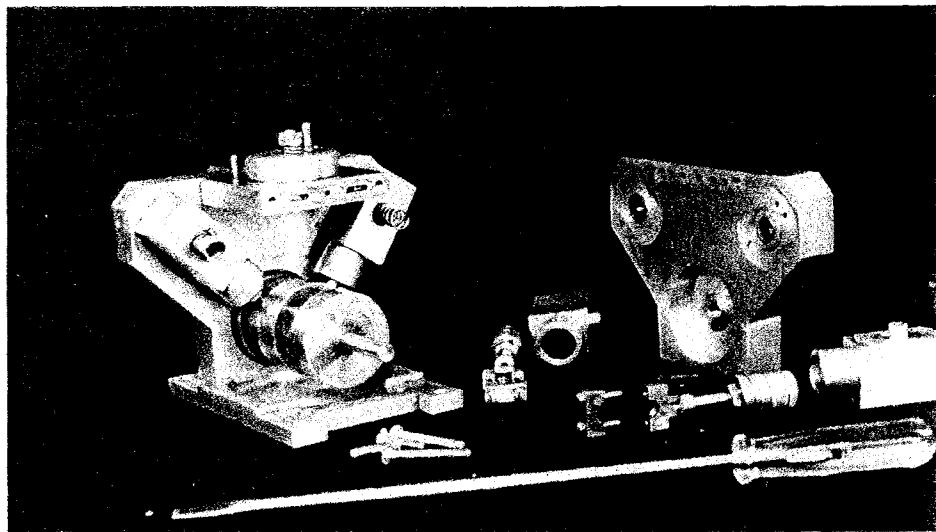

Partial assembly of the V4 Wobbler.

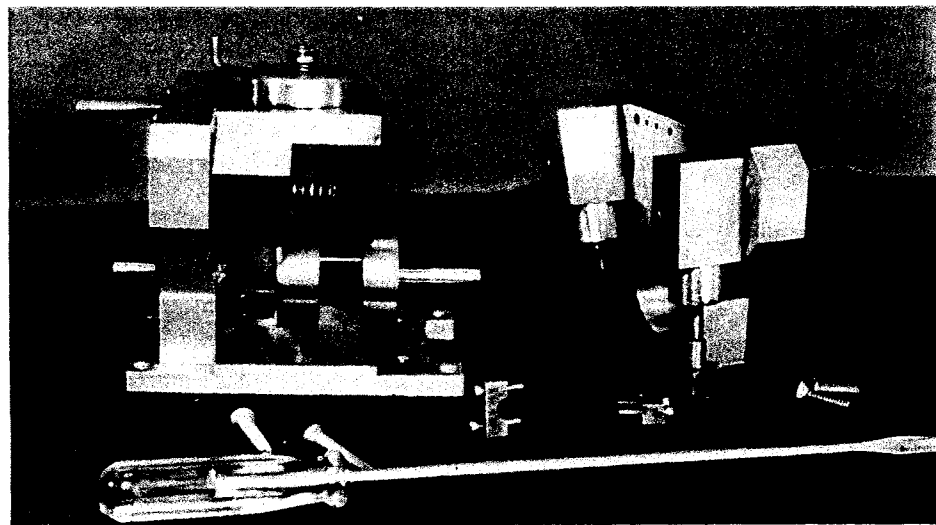

Bringing the sub-assemblies together for final assembly.

tate 180° for the second hole.

Assemble the two completed End Plates, Valve Plate and Foot. Measure across face to face between the Crank Bushings with an inside caliper. Transfer this setting to a slide caliper and lock the slide.

Loosely assemble the entire Crank Shaft. Apply Loctite **only** at the center disk **Crank Pin holes**. Set aside to cure. When set, assemble the two end Disks and Shaft and the center Disk assembly with Loctite. Hold the distance across the end Disks .005" less than the slide calipers.

Work out a marking system so all the parts can be reassembled the way they were fitted and worn-in.

The dimensions of the **SPRINGS** shown are based on the salvage springs used. Actually, the least amount of spring pressure to hold a seal is all you need, keeping the friction as low as possible. At assembly,

add thin steel disks in the Cylinder Spring holes, bedded in grease.

Assemble one End Plate, the Valve Plate, Crankshaft and two sets of Cylinders and Connecting Rods. Insert the Pivot Springs. Hold the other End Plate and two Cylinders together and bring them to this assembly, engaging the Pivot Springs. Hold together and insert the Valve Plate screws. Now insert the Pistons into their own Cylinders, rock around until the Connecting Rod Bearings engage the Crankshaft and fit the Caps in place.

Attach the Foot and the Valve and start your "fiddlin', fussin', filin' and fittin'." It takes a bit of this to make it run free and easy.

Even though there is the friction of four wobbling Cylinders, it takes only about 10 psi of air to spin this engine at a good speed after it is once broken in a bit.