

Una-Flow Engine

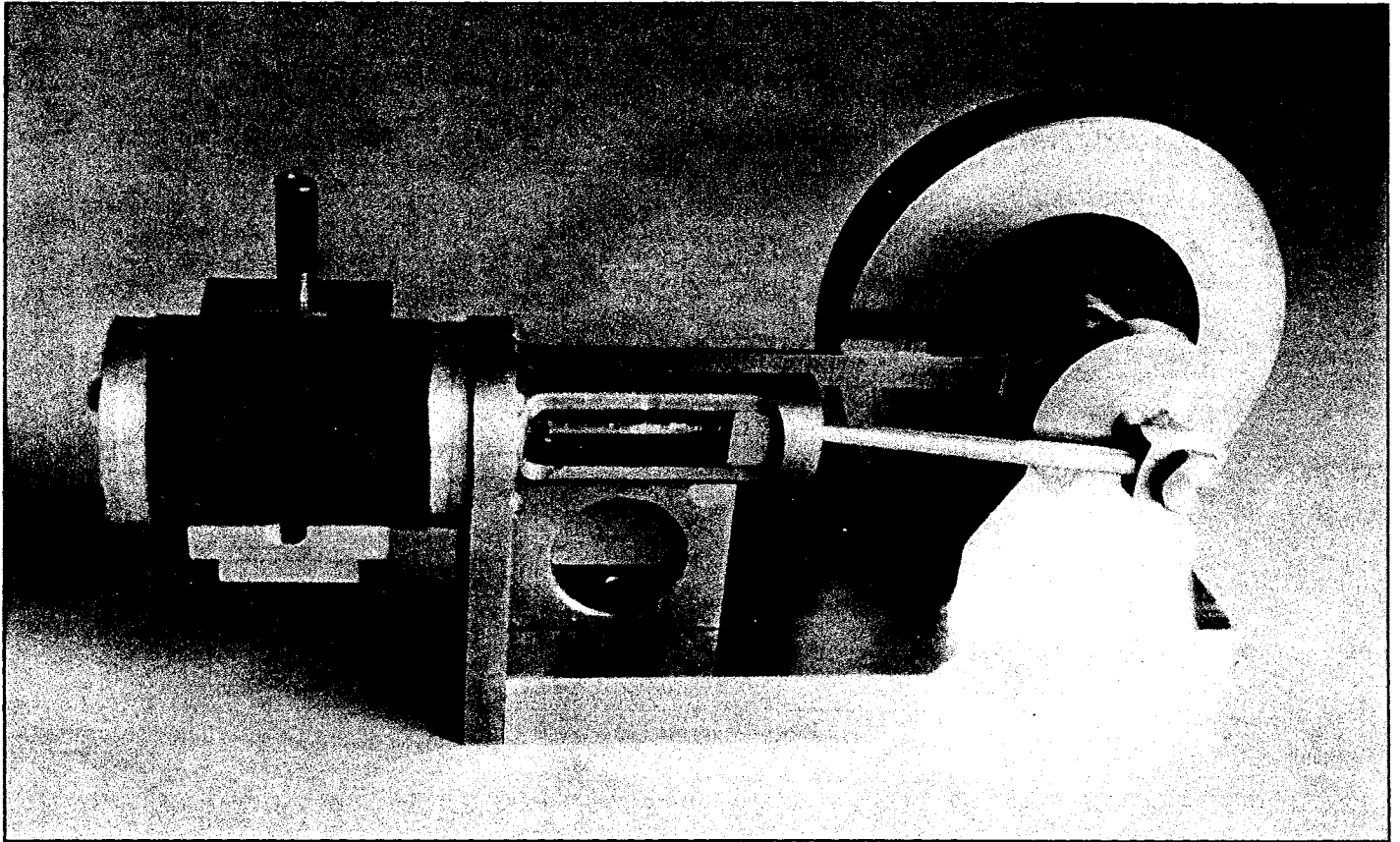

This model is an attempt to help beginners build a stationary engine using the Una-Flow principle. For all appearances, it looks like many of the past models. It is double-acting and the exhaust can be piped away and controlled. One thing gathered from past articles is that the Piston length is 9/10ths as long as the stroke. The steam does not reverse in the ports. The flow is continuous in one direction and the new steam entering is not cooled by passages that could be cooled by exhaust steam and moisture. There is a bit of back-pressure at the end of each stroke which acts as a cushion, and contributes to the action. Much has been written about this type of engine. Perhaps you can improve upon this design.

For a change, this one uses a Piston Valve which is quite simple, perhaps over-simplified. The Base is odd shaped, but can be plain rectangular.

The Block under the Crosshead Guide is used to take away some of the thin skeleton appearance. It can be omitted though and, if a screw is run up through the Base into this Block, it will add a bit of support to the Cylinder Plate.

The **BASE** doesn't need any mention except to suggest that the last operation should be cutting away to the odd shape.

The **CYLINDER PLATE** and **CROSSHEAD GUIDE** should both be brass for sake of easy soldering. While the Plate is still rectangular, lay out all centers, drill and counter-sink for #4 screws and drill #43. Chuck in the 4-jaw. Indicate true and centered for the 1/2" counterbore, making the seat for the Guide parallel to the face. The Guide is made by centering a piece of stock in the lathe and boring 3/8" for a fine-running fit for the Crosshead. The flats can be milled

in the cross slide milling attachment. Round the top of the Plate to 1/2" radius and solder Plate and Guide together.

Make the **BLOCK** under the Guide as plain or fancy as you wish. Attach to the Plate and solder to the Guide at the outboard end. Running a screw up through the Base into the Block makes a more rigid support.

The **BEARINGS** are simple and require little mention. An option, if made of aluminum, is to bore out and press in bronze bushings for the Shaft. Mounting on the Base and line-reaming is the surest way for a free-running Shaft. Mark them so they can be returned to the position at which they were machined.

The **FLYWHEEL** should be heavy so most of the metal is left in the blank. A pin is used instead of deep tapping for the set screw.

Center some 5/8" stock in the 4-jaw

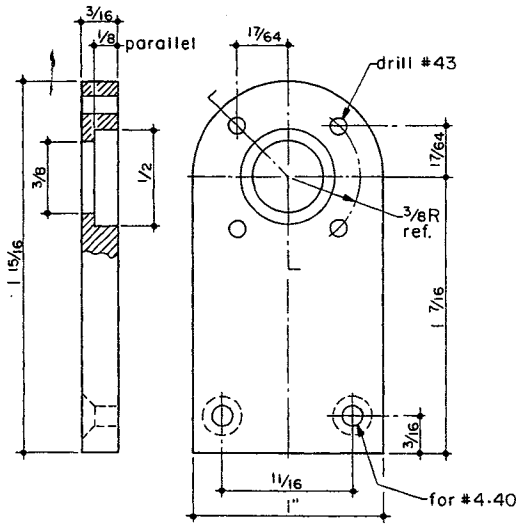

CYLINDER PLATE
Brass

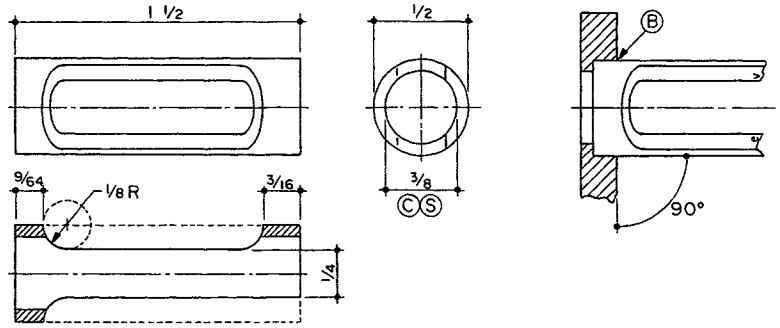

CROSSHEAD GUIDE
Brass

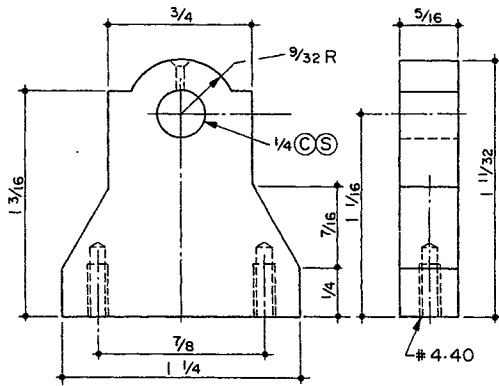

BEARING
Hard Aluminum
2 Required

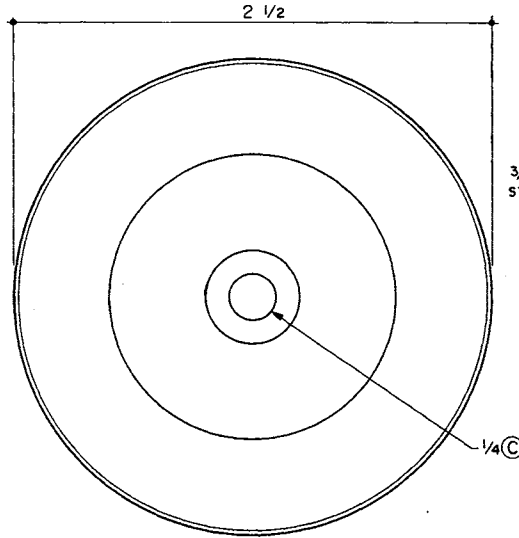

FLYWHEEL
Any Metal

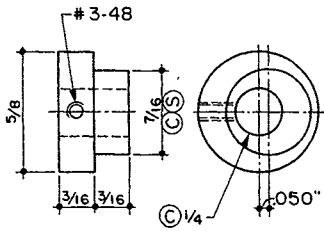
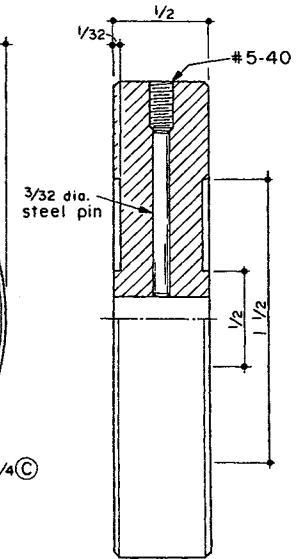

ECCENTRIC
Steel

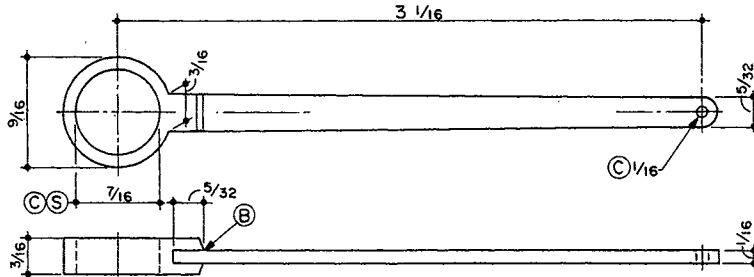

ECCENTRIC STRAP
Brass

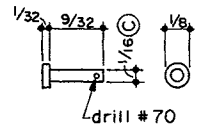

PIN
Brass

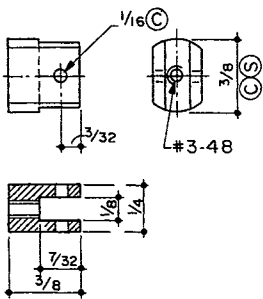

CROSSHEAD
Brass

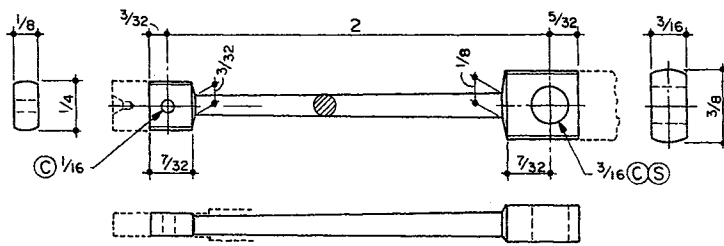

CONNECTING ROD
Brass

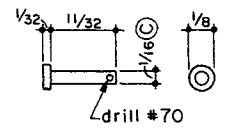

PIN
Brass

for the **ECCENTRIC**. Take a fine skin cut to brighten the O.D. and bore the 1/4" Shaft hole. Offset .050" and then turn the 7/16" diameter. One suggestion is to mount a square-ended bar in the tool post and bring it up against the stock. Zero the cross slide collar. Turn the chuck so two jaws are horizontal. Ease off the vertical jaws slightly and back up the rear jaw about 1/16" Push the stock back to the rear using the front jaw. Advance the cross slide .050" and ease the stock back against the bar, using the rear jaw. Snug up all jaws. Now, when the high spot just kisses the bar and the chuck is rotated 180°, a .100" diameter rod should just pass between the bar and the stock. You are now ready to turn the 7/16" diameter. Spot the set screw on the centerline through the offset. It helps when timing the engine.

The **ECCENTRIC STRAP** is made of 3/16" stock, laid out, bored, sawed, filed to shape and then soldered to the 1/16" stock. Measure 2-27/32" from the edge of the hole to locate the 1/16" hole at 3-1/16" center to center.

For the **CROSSHEAD**, center some bar stock in the lathe and turn to 3/8" for a close, free fit in the Guide. Tap 3-48 at least 3/8" deep. Transfer the stock to the cross slide mill and cut to 1/4" thick. Mill the 1/8" slot and cut off at 3/8" long. Lay out and drill for the 1/16" pin. Run a tap through to clean up the 3-48 hole.

The **CONNECTING ROD** starts with some 3/16" x 3/8" stock. Lay out

the 3/16" and 1/16" hole centers and drill and ream. Mill to the 1/8" thickness for about 1/2" from the end. Allow stock for chucking and tailstock support. Turn the shank with the compound set at about 3 or 4 degrees. Start at the small end and watch when the cut runs out. Adjust the compound very slightly if the cut does not run out near the 1/8" diameter at the large end. It is not serious if the dimensions do not meet the print as long as it looks good to you.

Lay out all centers and lines on an accurate 1" x 1" x 1-3/8" block for the **CYLINDER**. Note the 1/2" bore is 15/32" from the faces at one corner of the 1" square. Drill and tap 2-56 for the Heads, the Valve and the Exhaust Cover. Mill the two 3/32" x 1/4" slots for the steam passages. Drill the two 1/16" holes at 14°. Drill the four 1/16" holes for the Exhaust at least 3/8" deep. Drill #23 across these four holes for tapping later at 3/16-40 MTP. Center in the four-jaw for boring 1/2" and turning one 15/16" flange as in **Step 1**. Reverse and turn the second flange. Make a milling setup for **Steps 3, 4 and 5**. Filing **Step 6** is optional. Tap 3/16-40 MTP and mill to the 1/8" dimension at the 14° passages.

Make the **LAGGING** from thin sheet stock. Trace from a cut-and-fit paper pattern. Roll over about a 5/8" or 3/4" round bar so it will spring into place.

The **VALVE BODY** is quite simple but requires a very accurate and

smooth passage for the Valve. Lay out all the holes on a 3/8" x 5/8" x 7/8" block. Center in the four-jaw and bore 1/4". Drill the six #56 holes, the 3/32" hole and the four #43 holes. Enlarge the 3/32" hole and tap 3/16-40 MTP. This is a shallow tapping job but it is preferred that the hole entering the 1/4" bore should be no larger than 3/32". An option is to counter-drill a shallow 3/16" diameter hole and solder a short piece of 3/16" tubing for use with common 3/16" aquarium tubing.

The **VALVE** and **CLEVIS** are fairly simple and about the only mention would be to make the O.D. the closest free fit you can. The slot helps in centering the Valve travel.

The **PISTON** is another close fit job. There is adjustment here for centering the Piston travel in the Cylinder. There is a 3/8" x 3/32" recess in each end in an effort to reduce somewhat the back pressure at the end of the stroke. Centering the Valve and Piston travel is critical to a smooth running engine. It may take several trials to achieve.

At final assembly, set the centerline through the Eccentric offset at 90° from the centerline through the Crank. The engine shown required a bit more speed than past slide valve engines and pressure around 25 psi. The exhaust sound is sharper. This is an interesting engine but not easy to explain at an exhibit. There is nothing on the outside that shows the principle of Una-Flow.

