

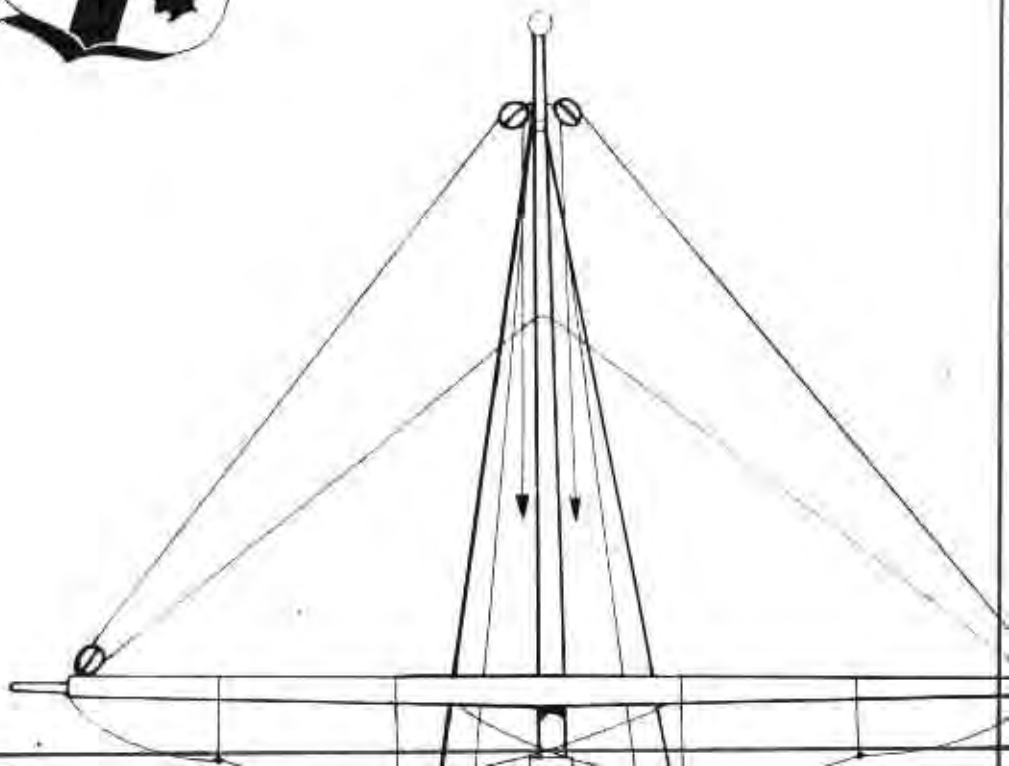

.. Vanita .. se

Brigantino Spagn



spherical agents - the drawing on this sheet may undergo some deformation in size -

c. 18°
nolo

BARCA
BARCASSE
Launch
Chaloupe

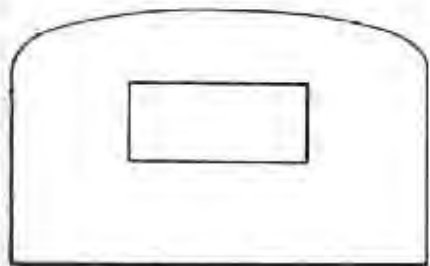
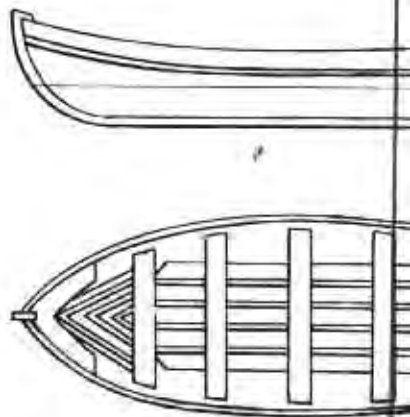

DALL' ALTO

DAL BASSO

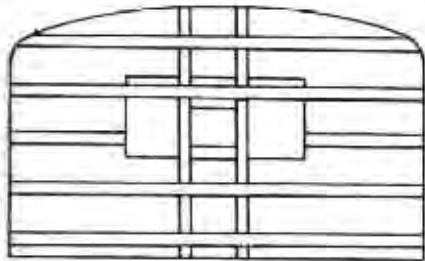

COFFA DELL' ALBERO MAESTRO

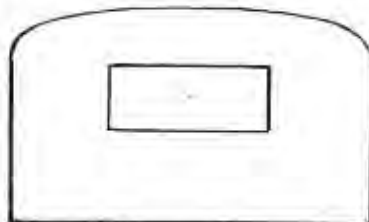

DALL' ALTO

DAL BASSO

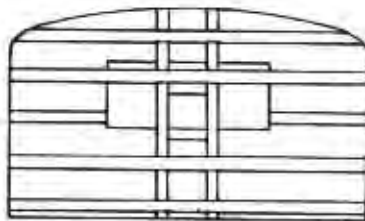

COFFA DI TRINCHETTO

N.º 9. Because of the frequent dilatation of paper - owing to stress.

continued -

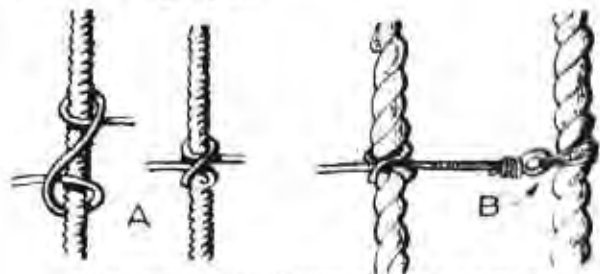

LE GRIFFER DAN
L'ARTI ALLI SARTI
DOL NODD PAMEA
PHEIRA ED ALLI OCT
DOL SYSTEMA MUS
FIG. B -

Les enflechures
sont fixées aux haubans
durant l'illustration
le premier et le
haubans, leur rôle

DIE WEBELEINEN MÜSSEN MIT EINEM WEBELEINENSTICH A. SE DOCH
BZW. LETZTEN WORT NACH DEM IN DER ABILDUNG B BEZEICHNETEN
WERDEN -

Ratlines should be fixed to the shrouds by means of a clove hitch
knob A and to the mast by the method shown in B.

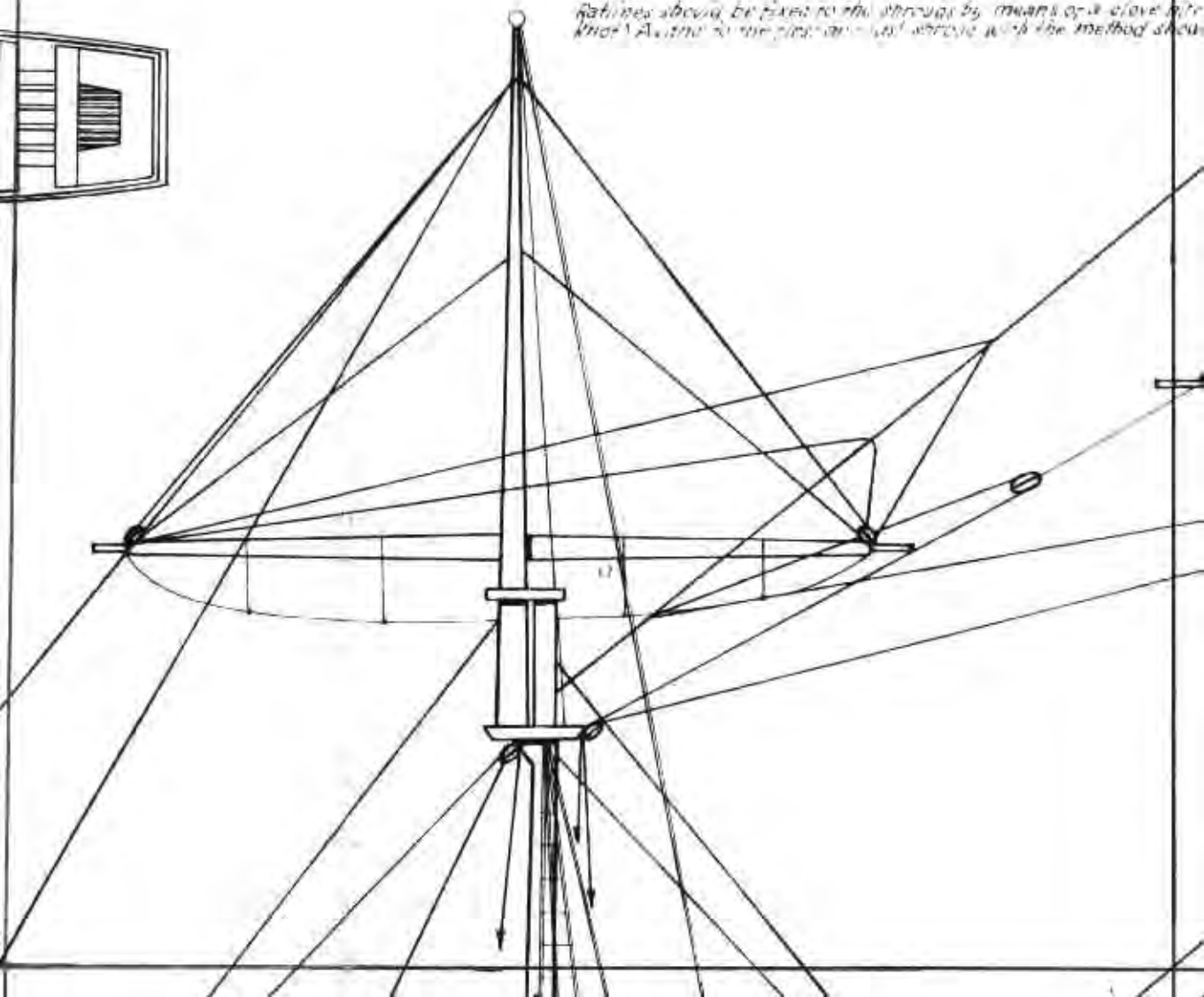
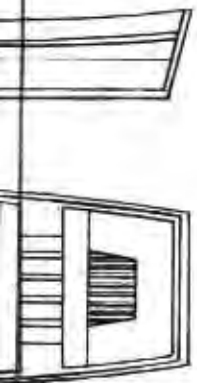

...die Fyrtårer Buih...
...the corresponding masts without in Author's written allusion...
...PARTICOLARE DI...
...KLANE -...
...SCHWARZ...

DEVONO ASSIEME
PARTI CENTRALI
RELATO A ED ALLA
MULTIPLA PARTIA
MOSTRATO DALLA

...s doivent être
...bans par le moyen
...stré en A. Pour
...le dernier
...fois, voir fig. 8 -

DEH AN DER ERSTEN
SYSTEM, BEFESTIGT

...ich (Dr. B...
...in fig. 8 -

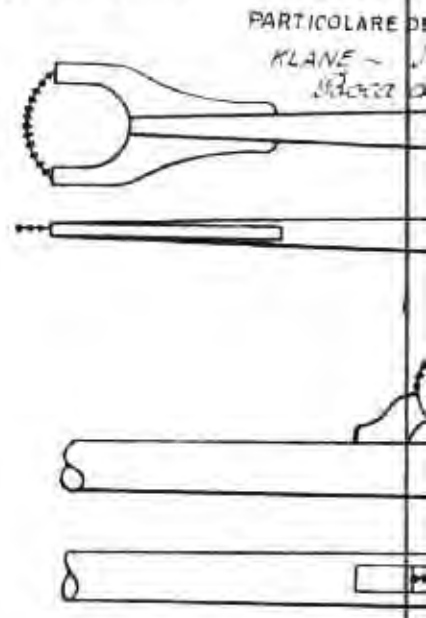
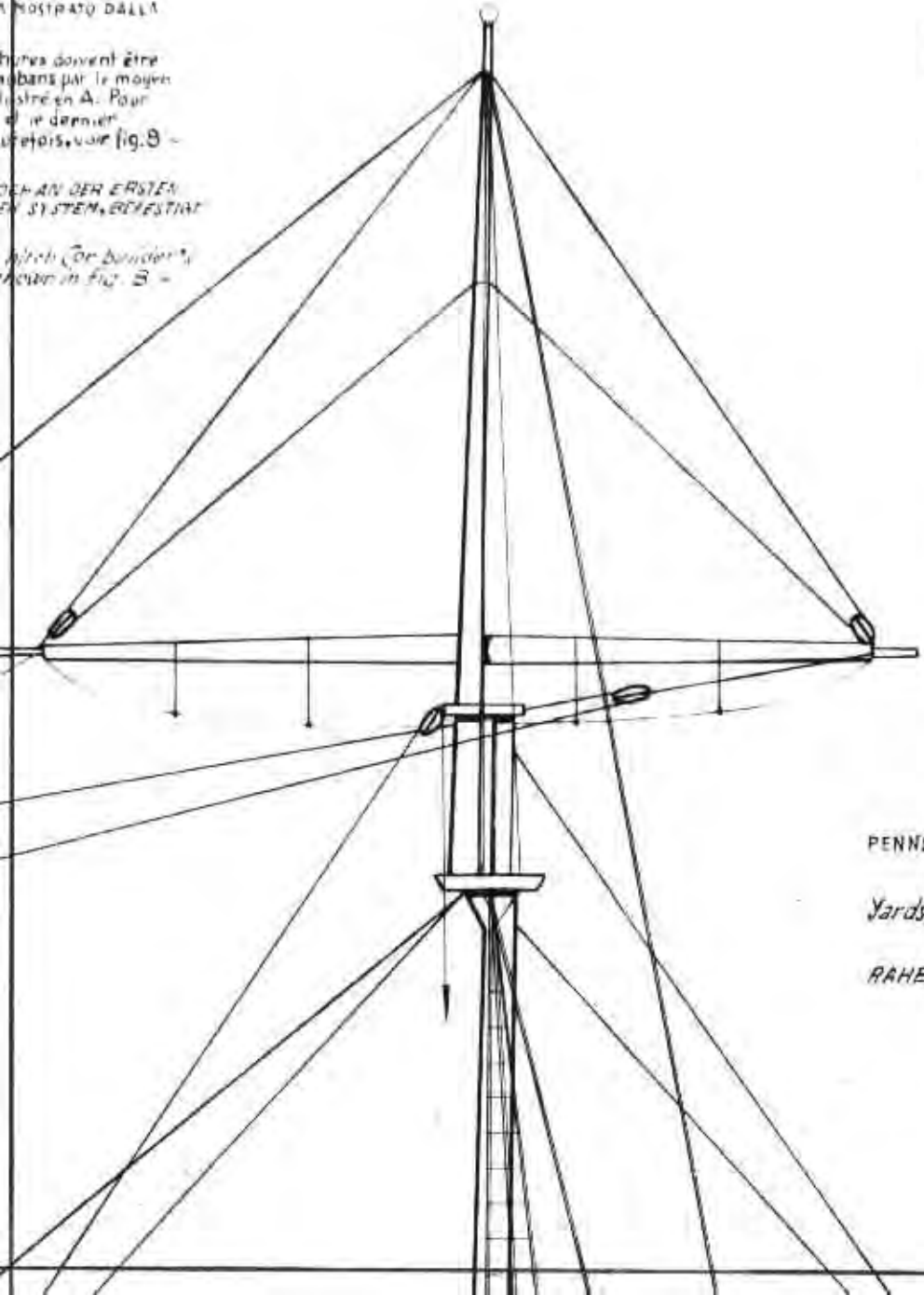

PENNONI, NERI.

Yards, black.

RAHEN, SCHWARZ.

E DELLA GOLA DEL PICCO ~
Law ~ Mâchoire ~
de canchero ~

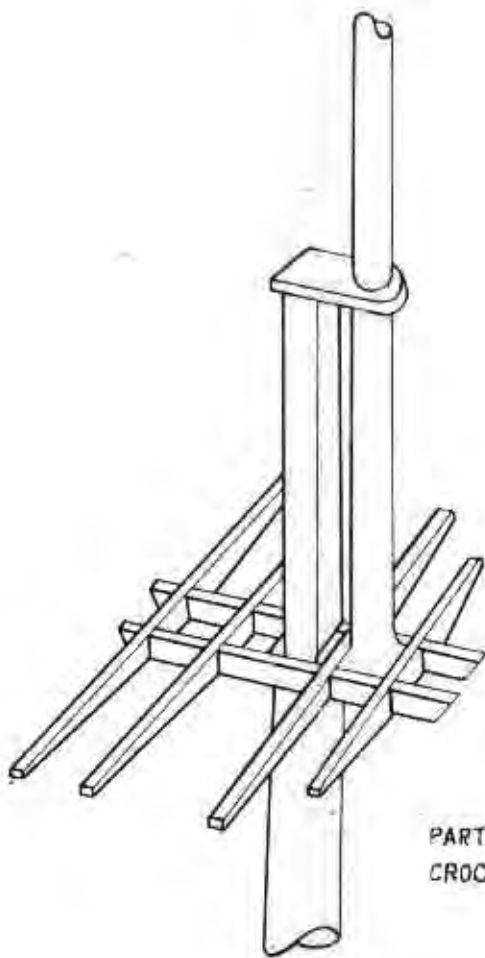
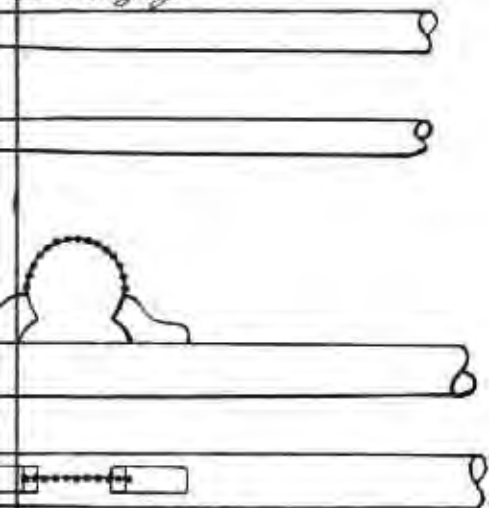

PARTICOLARE DELLA
CROCCETTA.



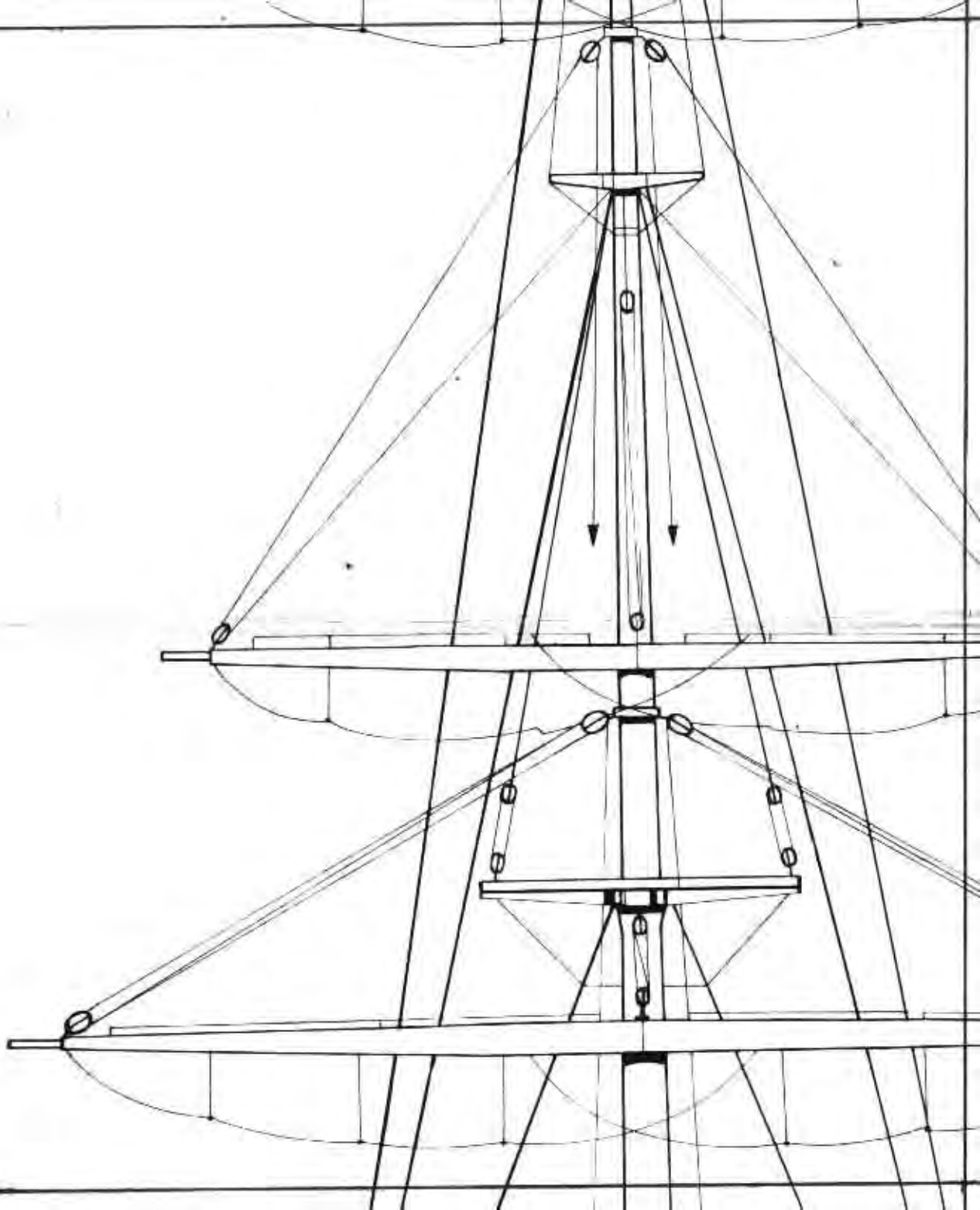

des pièces relatives sont défendues. Droit de rémunération réservé.

N. 3. L'éventuelle dilatation du dernier, causée par le

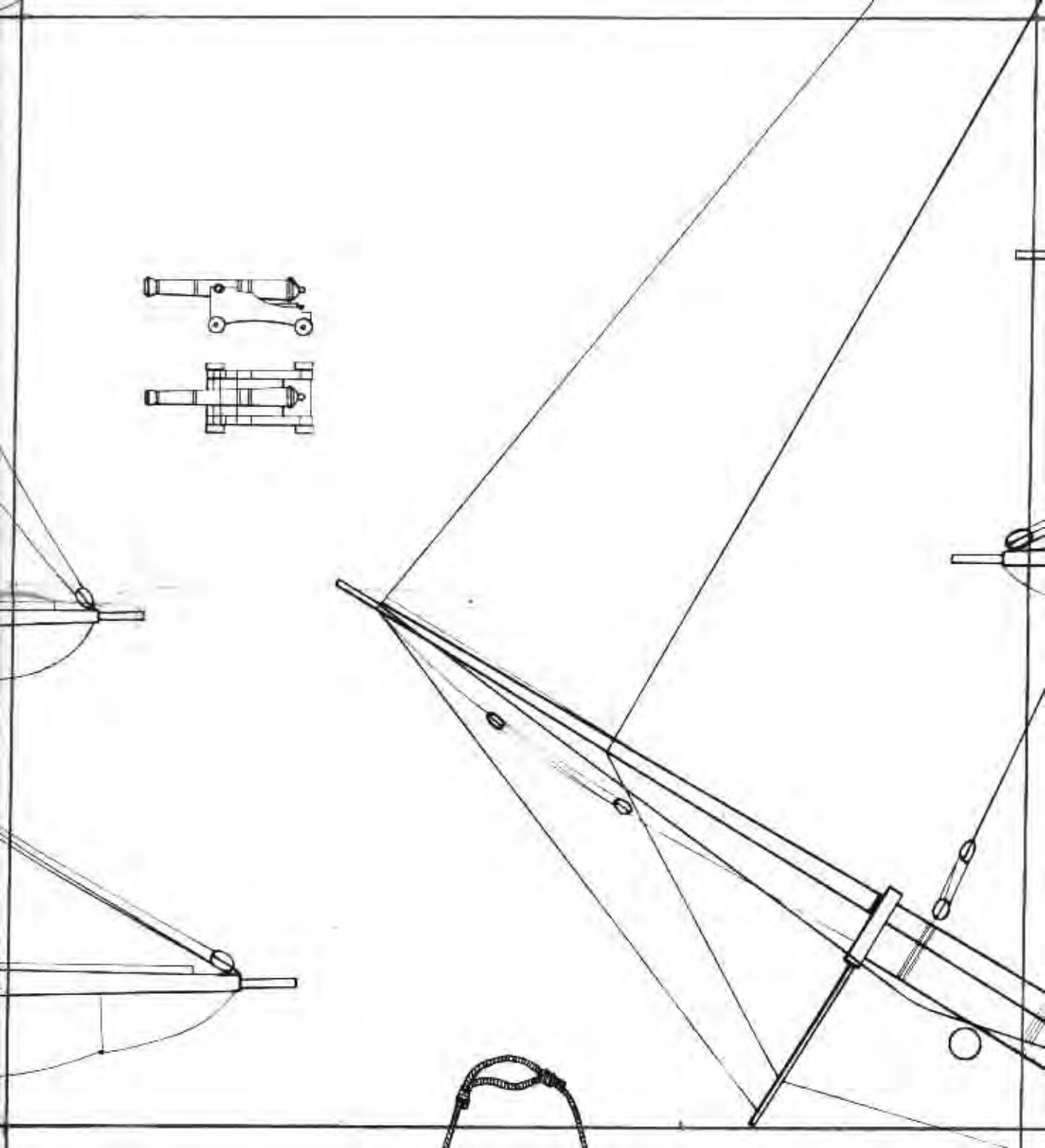

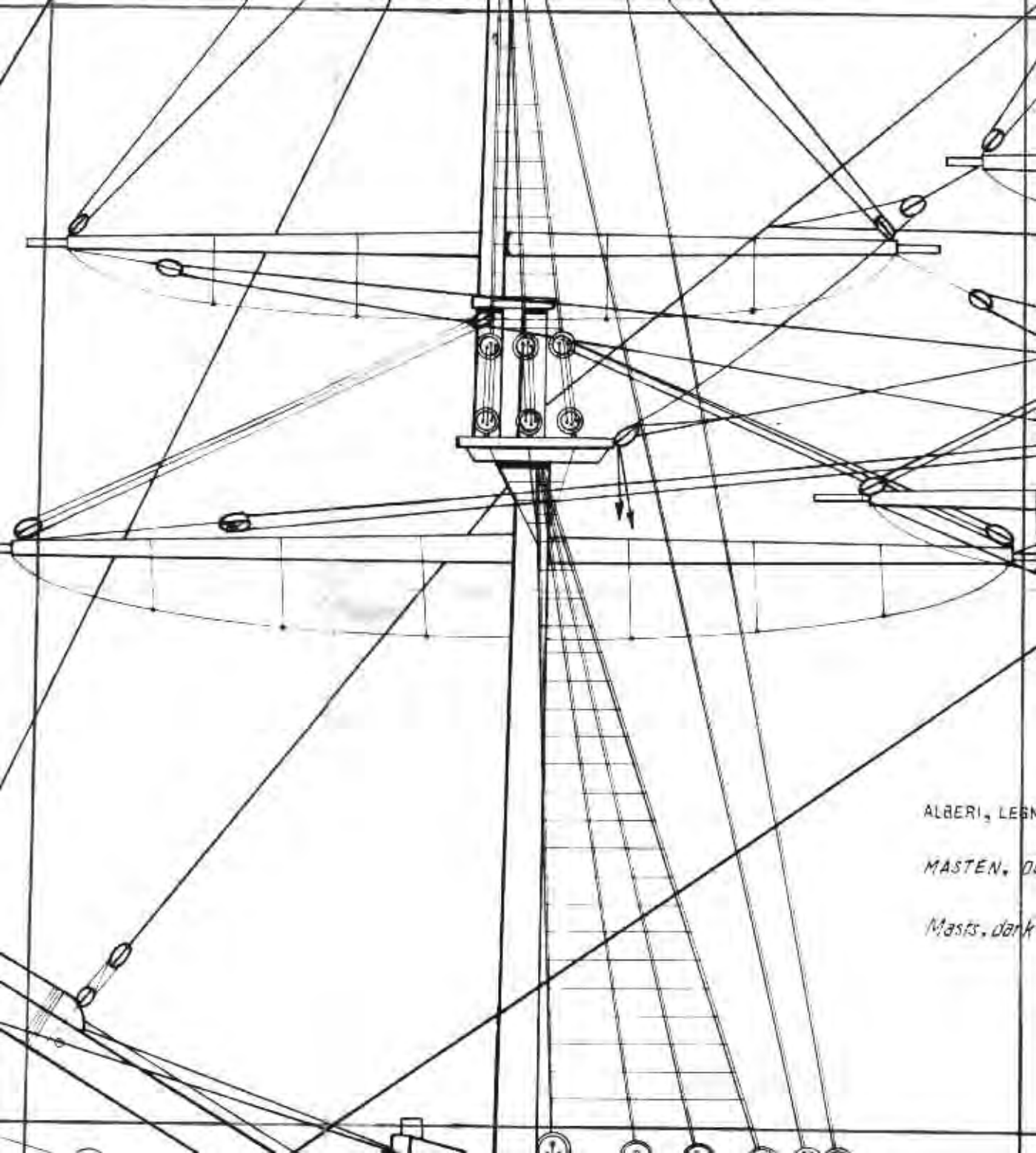

ALBERI, LEON

MASTEN, D

Masts, dark

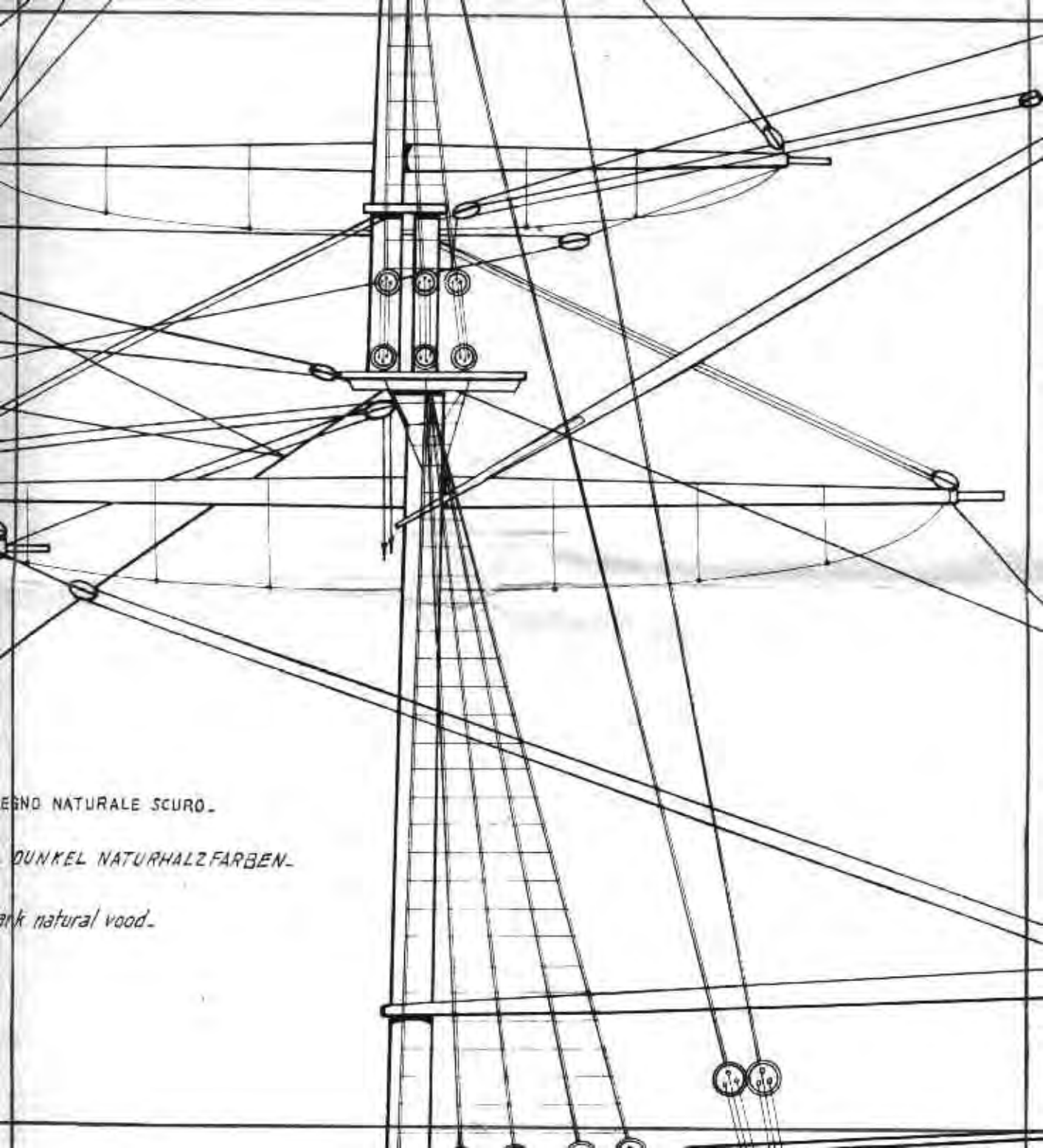

LEGNO NATURALE SCURO.

DUNKEL NATURHALZFARBEN.

dark natural wood.

AGUGLIOTTI E FEMMELLE PER FISSARE IL TIMONE ~

RUDERNAKEN MIT FINGERLINGEN ~

Rudder hinge pins and gudgeons ~

Aiguillots et femelots ~

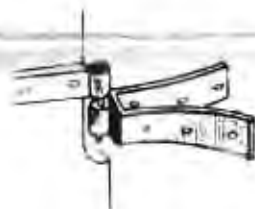
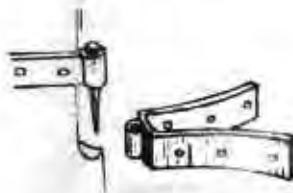
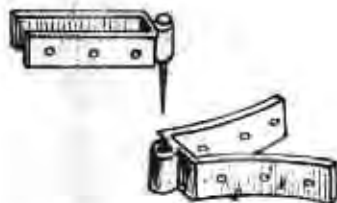

par les appareils atmosphériques, peut causer une petite déformation au décom-

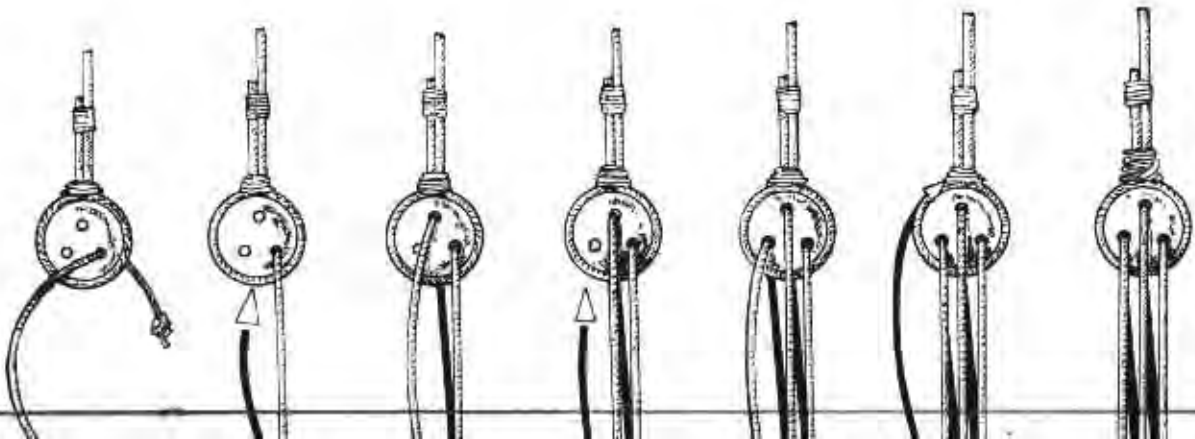
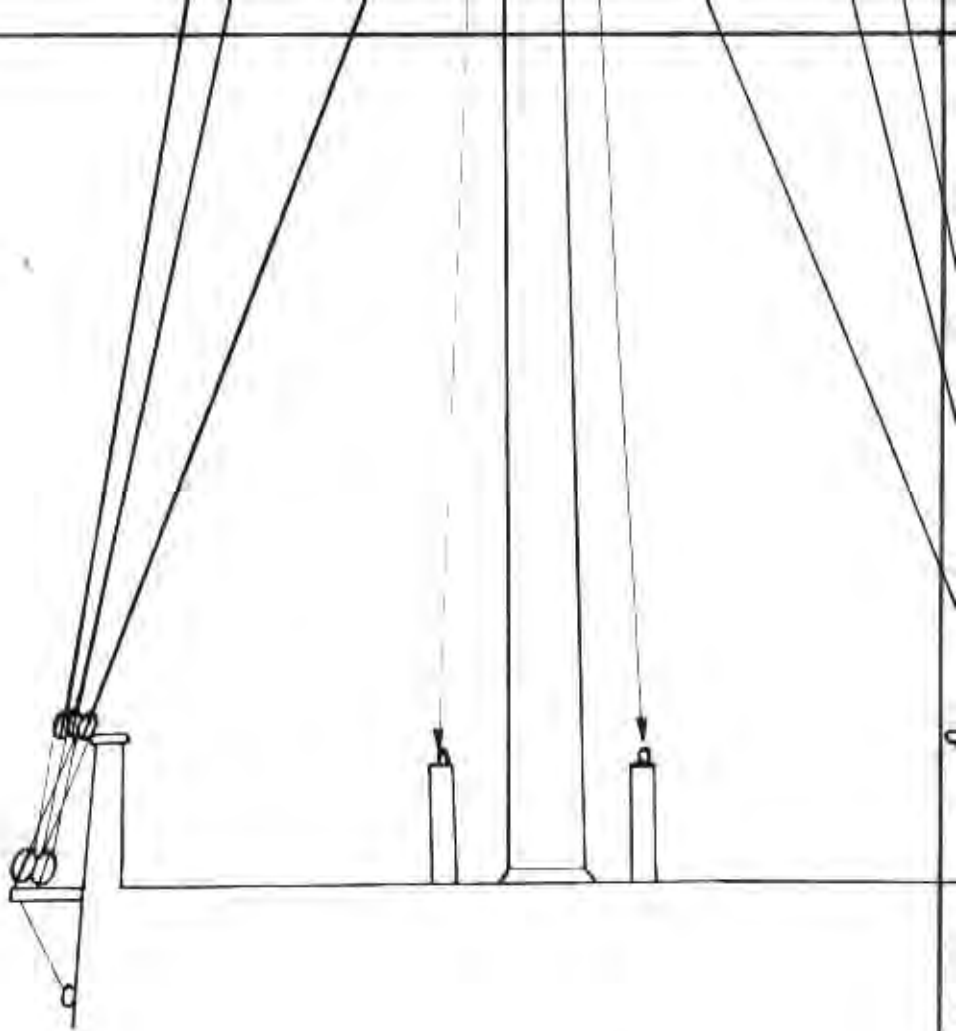

COMPL
ARIDAT
PATERA
Comme
habitant
ANSE
UND A
How to
and the

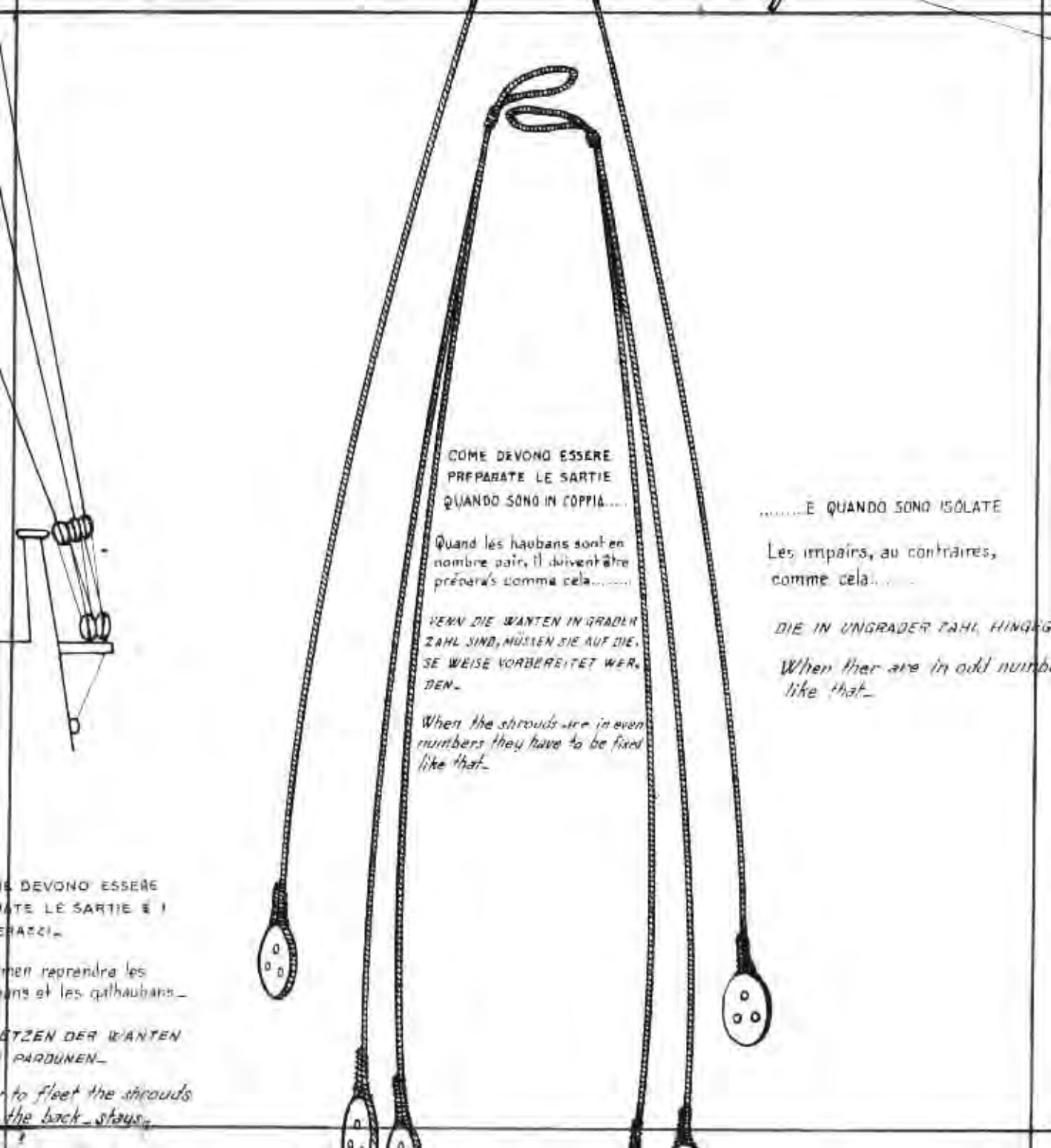

COME DEVONO ESSERE
PREPARATE LE SARTIE
QUANDO SONO IN COPPIA....

Quand les haubans sont en
nombre pair, il doivent être
préparés comme cela.....

WENN DIE WANTEN IN GRADEN
ZAHL SIND, MÜSSEN SIE AUF DIE
SE WEISE VORBEREITET WER-
DEN.

When the shrouds are in even
numbers they have to be fixed
like that.

.....E QUANDO SONO ISOLATE

Les impairs, au contraires,
comme cela....

DIE IN UNGRADER ZAHL HINGEGE

When there are in odd number
like that.

LE DEVONO ESSERE
PREPARATE LE SARTIE È I
ERAZZI.

men reprendra les
haubans et les galhaubans.

SETZEN DER WANTEN
PARDUNEN.

to fleet the shrouds
the back-stays.

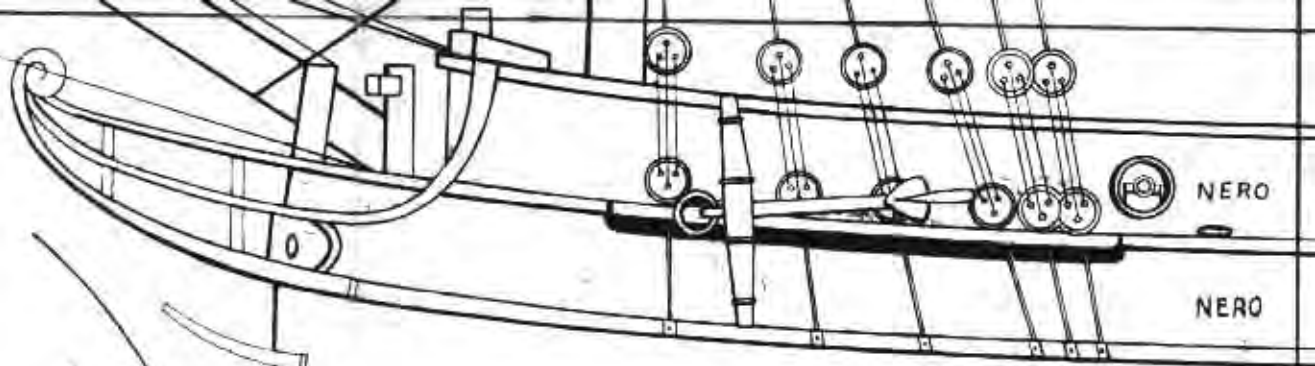

NERO

NERO

ROSSO POZZUOL

OPERA VIVA: BIANCO SPORCO

Quick-work: dull white

TOTES WERK: MATTWEISS

VEGGEN SO-

umbers.

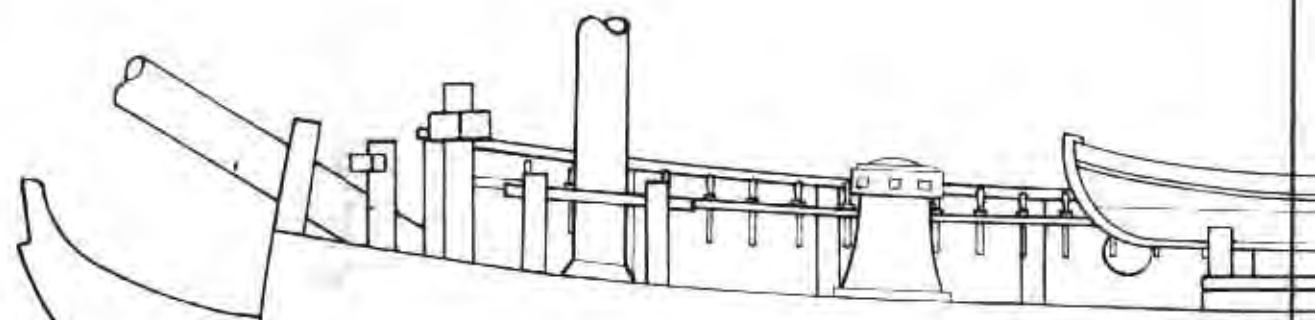

SPACCATO CON LA LINEA DEL PONTE

1 2 3 4 5

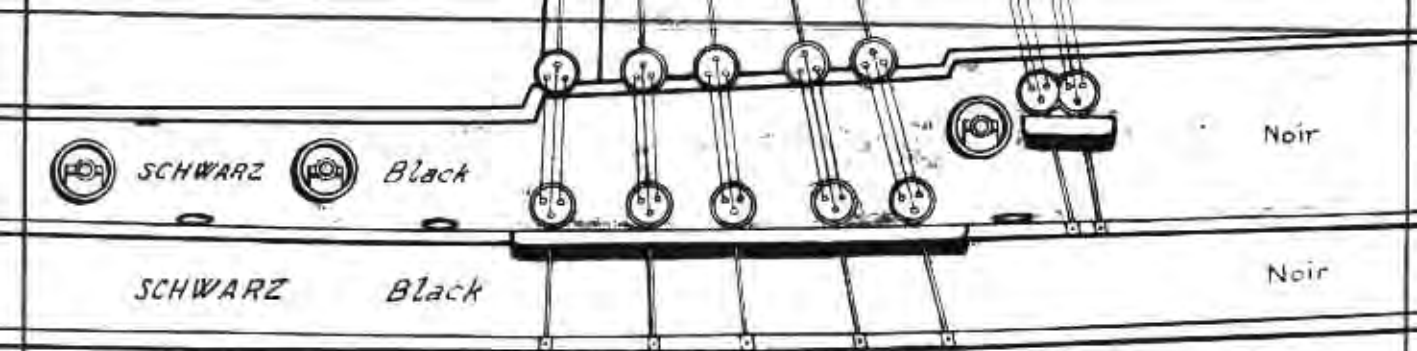

POZZUOLI - Pozzuoli red - POZZUOLI ROT - Rouge Pozzuoli

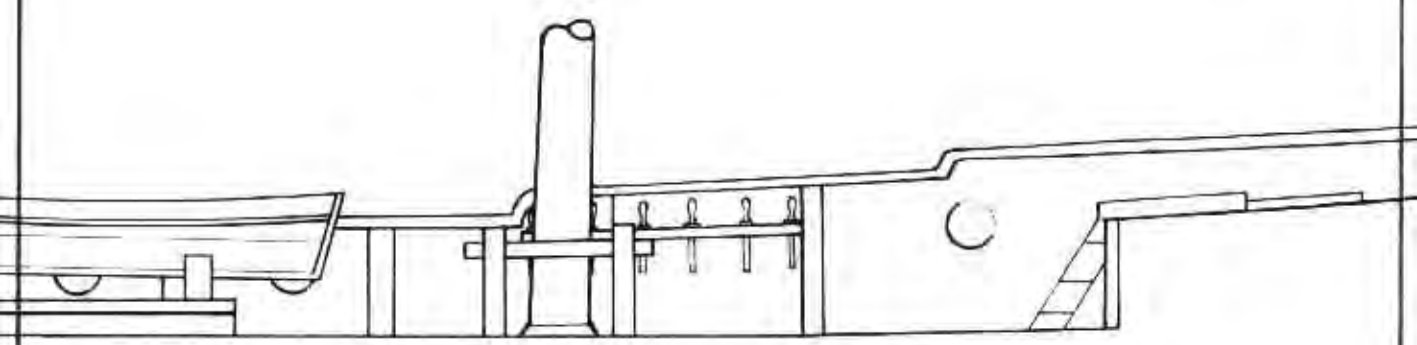

QUERSCHNITT MIT DECKLINIE ~ Section with the deckline ~ Coupe-au-maitre

6 7 8

bazuoli

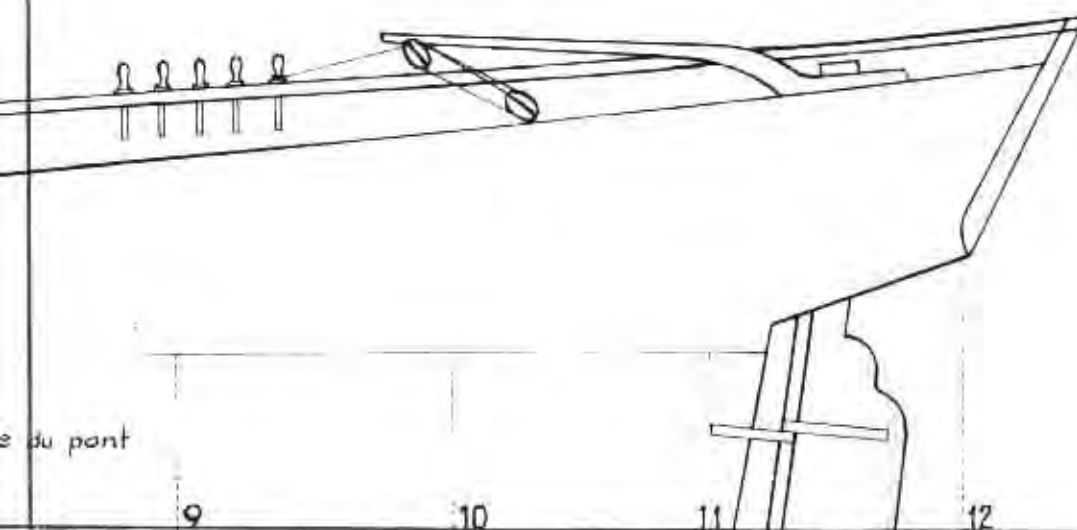
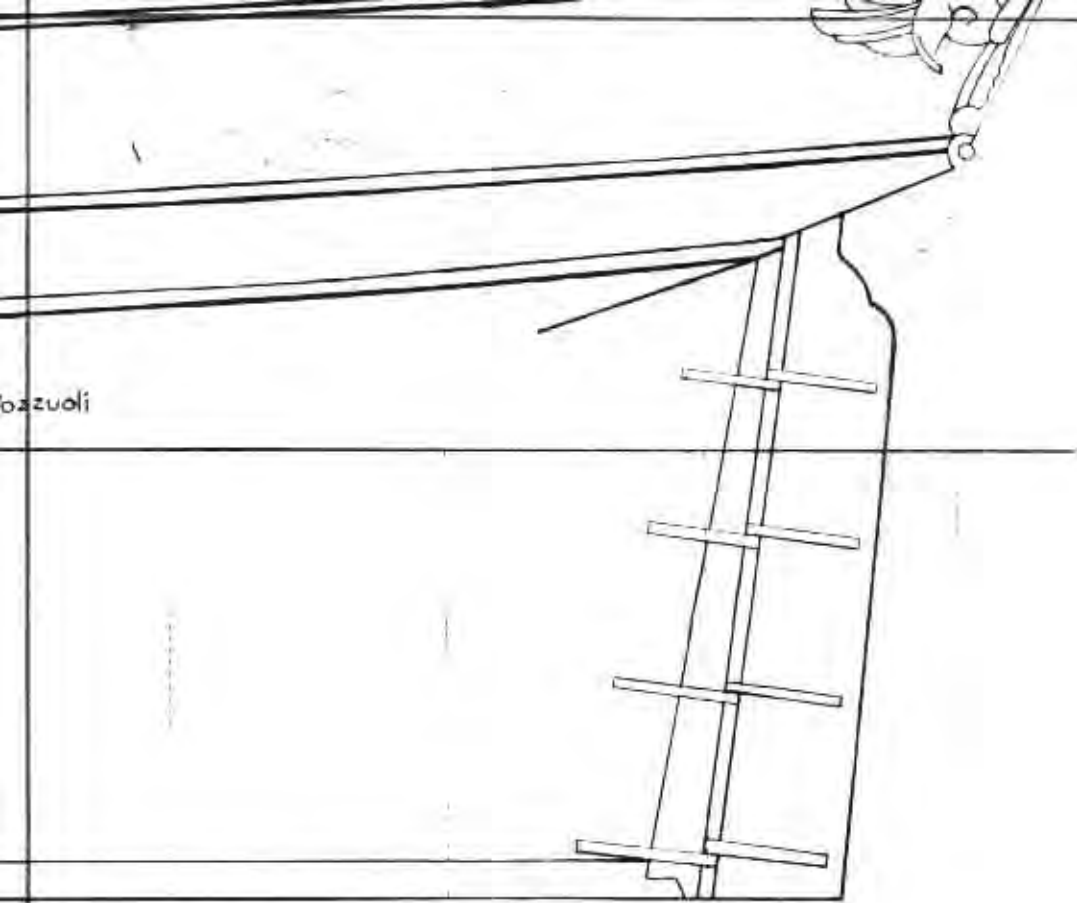

e du pont

9

10

11

12

— DANNE SCHRIFTLICHE EINWILLIGUNG DES URHEBERS VERBOTEN — ANSPRUCH AUF VERGÜTUNG FÜR DIE HERSTELLUNG VORBEHALTEN —

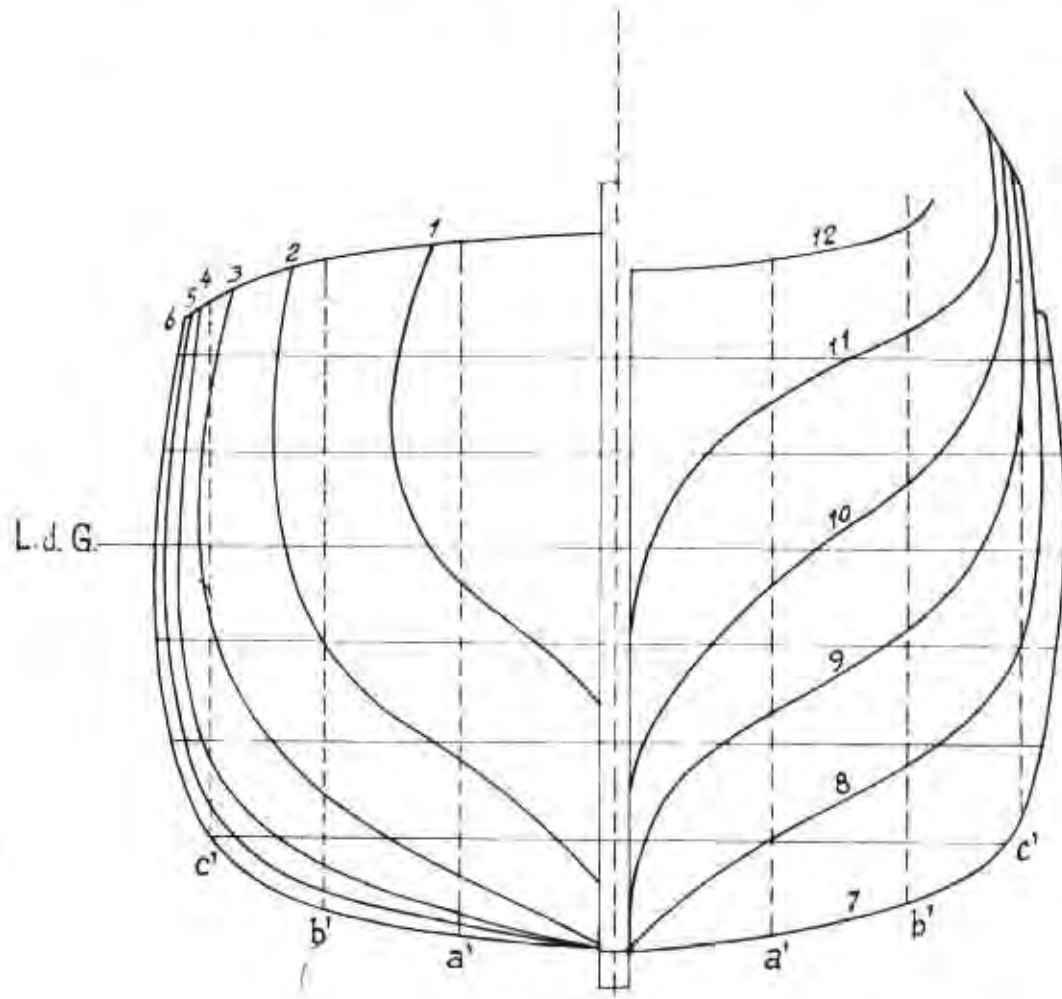
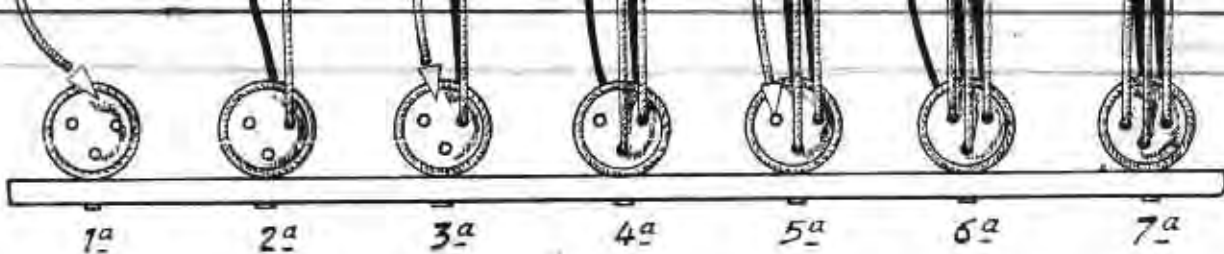

RIF 19 **1**

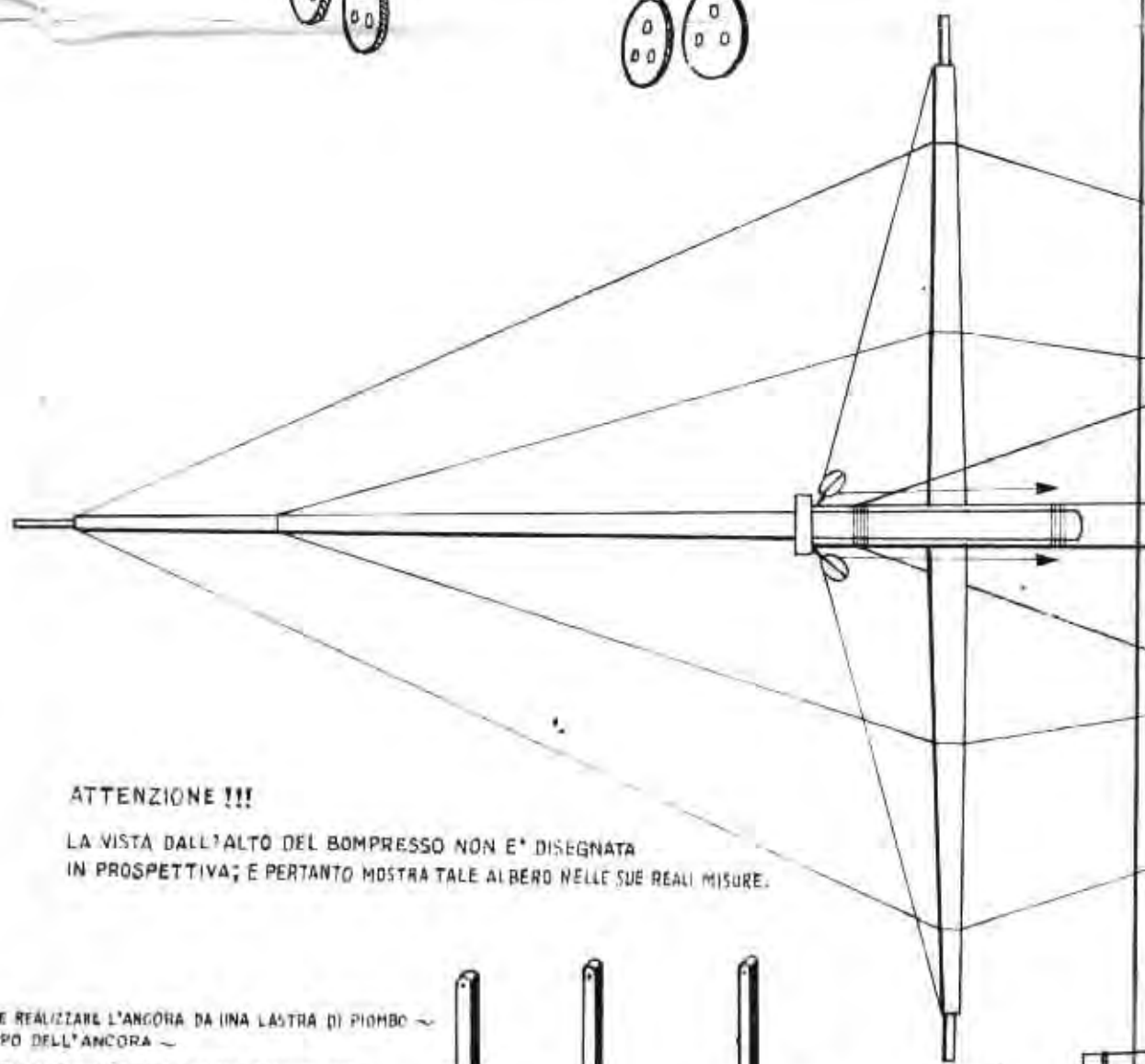
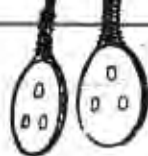
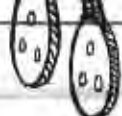

L. J. G.

ATTENZIONE !!!

LA VISTA DALL'ALTO DEL BOMPRESSO NON E' DISEGNATA
IN PROSPETTIVA; E PERTANTO MOSTRA TALE ALBERO NELLE SUE REALI MISURE.

- A - COME REALIZZARE L'ANCORA DA UNA LASTRA DI PIOMBO ~
- B - CEPPO DELL'ANCORA ~

ANKER: IHRE HERSTELLUNG AUS BLEI ~
Anchors and how to make them of lead ~
Ancres; comment les faire en plomb ~

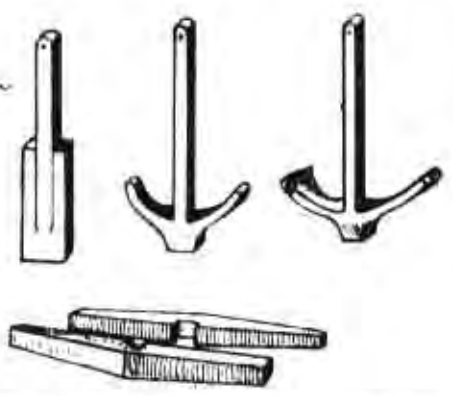

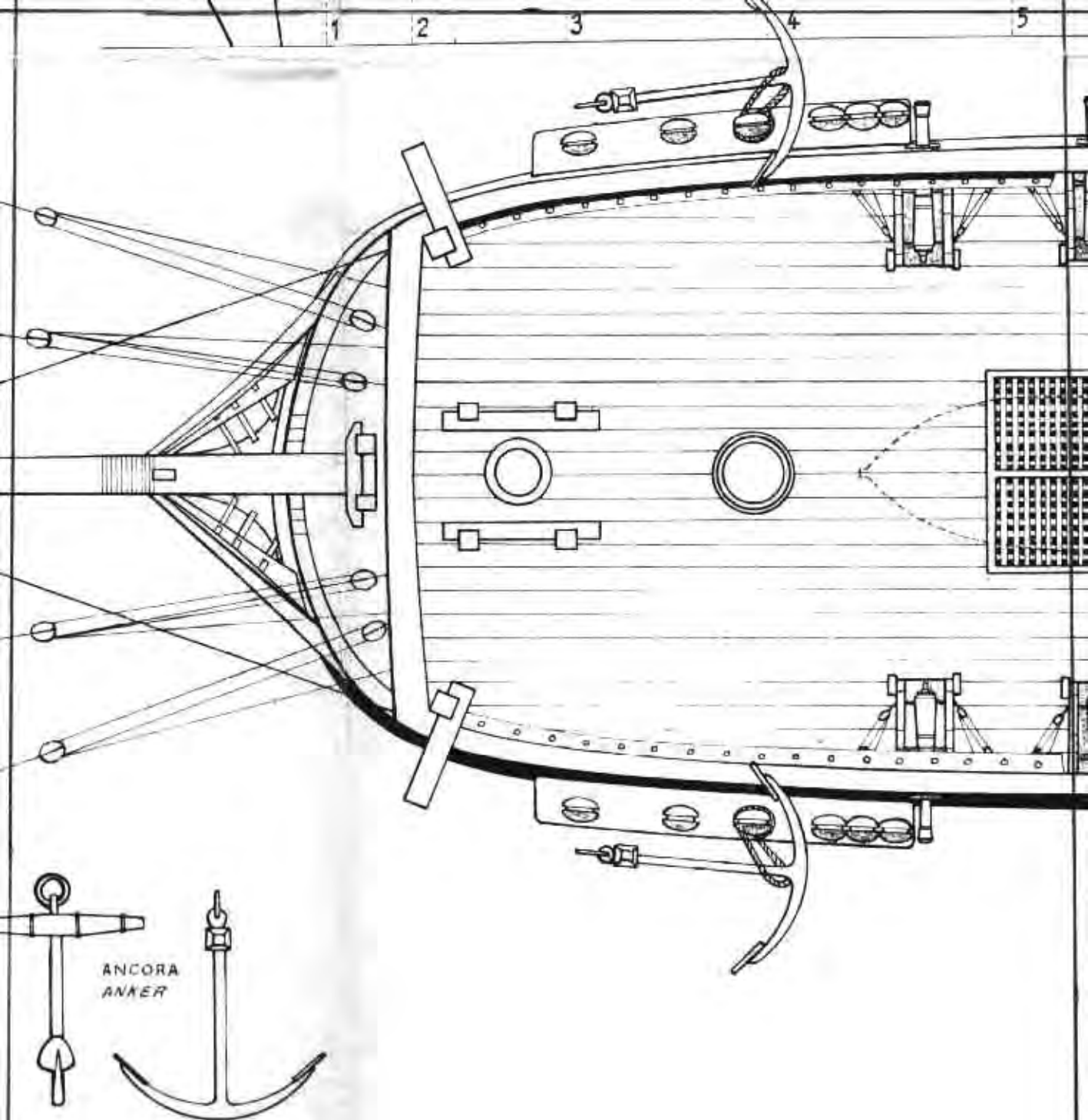

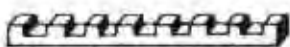
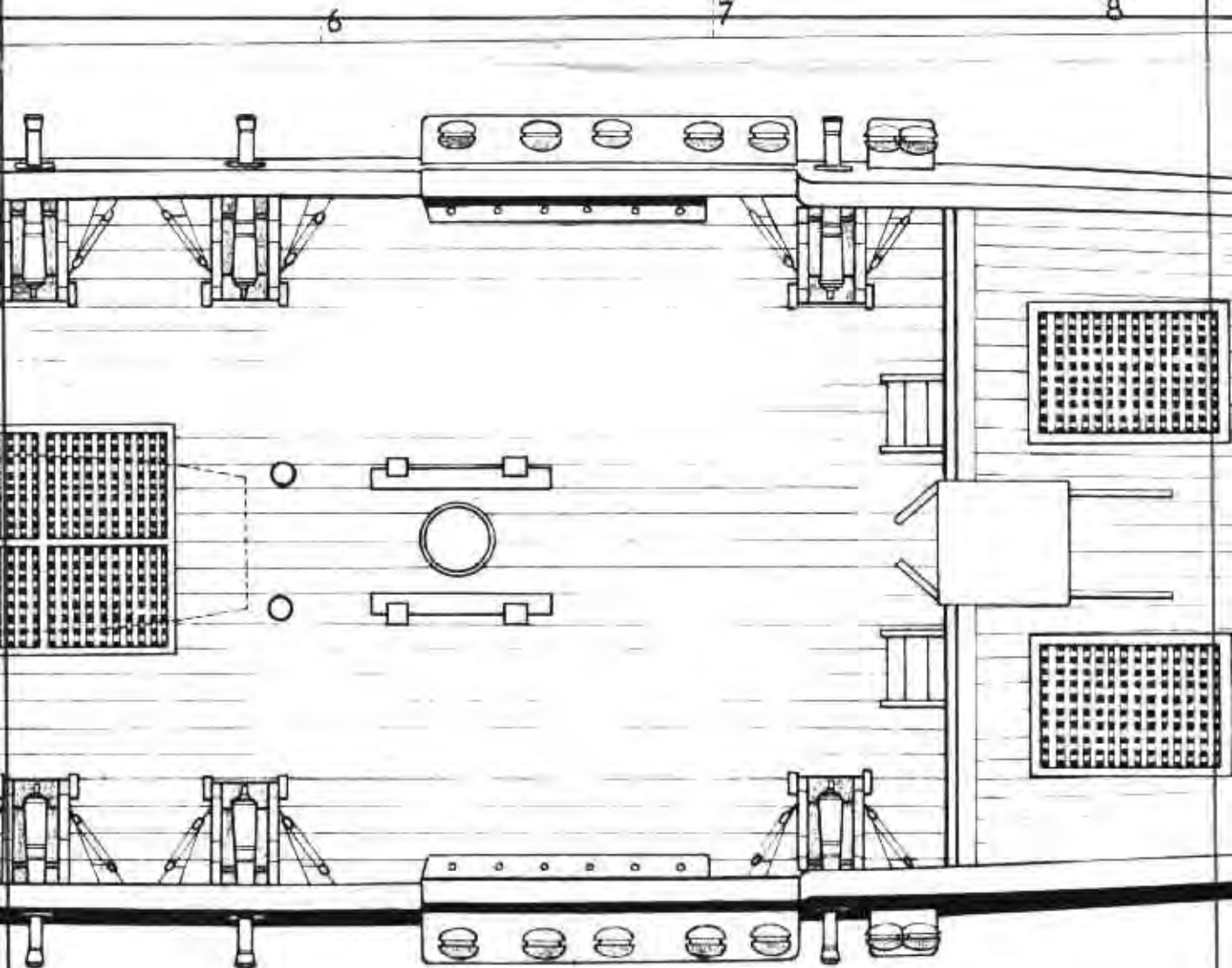

COME REALIZZARE I CARAB

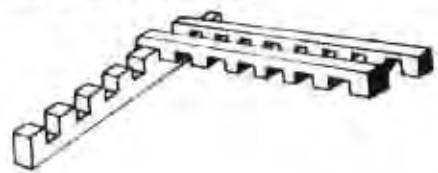

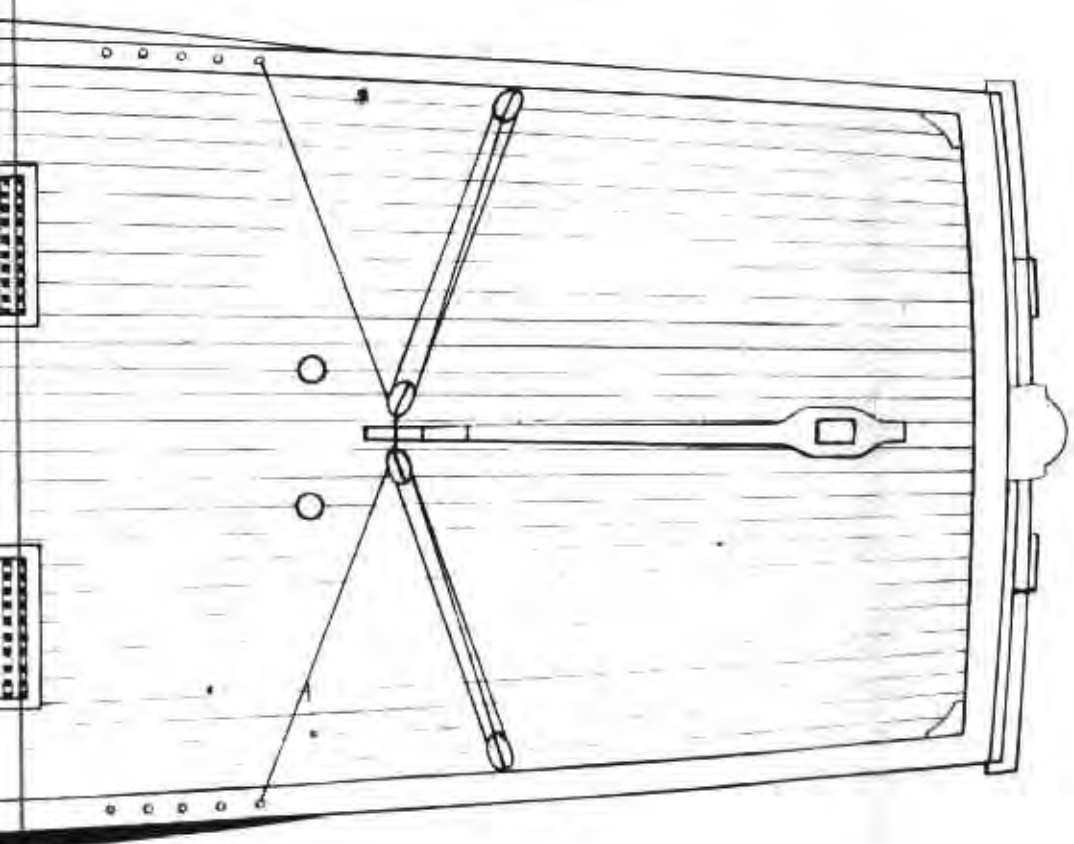

LABOTTINI IN LEGNO



KOMMERZIELLE NUTZUNG DIESER PLÄNE SOWIE DIE HERSTELLUNG VON MONTAGE-KÄSTEN FÜR DAS BETREFFENDE MODELL SIND ÖRN.

Vanita „ sec. 18^o
Brigantino Spagnolo



TUTTE LE ORDINATE DEVONO ESSERE FATTE IN COMPENSAIO DA
4 MM. —

ALLE WÄNTE WERDEN AUS EINER SPERRHOLZPLATTE
VON 4 mm DICKE NEHGE STELLT.

All the frames have to be made of plywood, 4 mm.

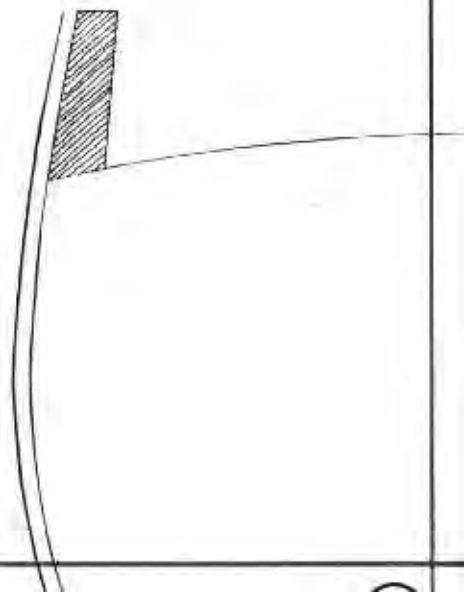

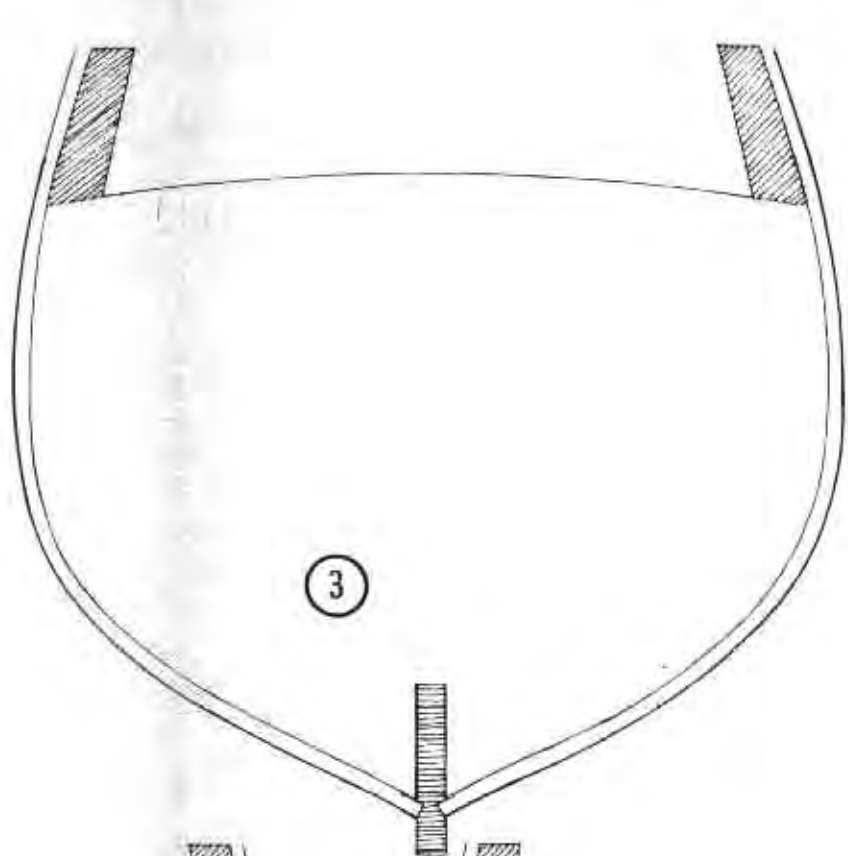

5

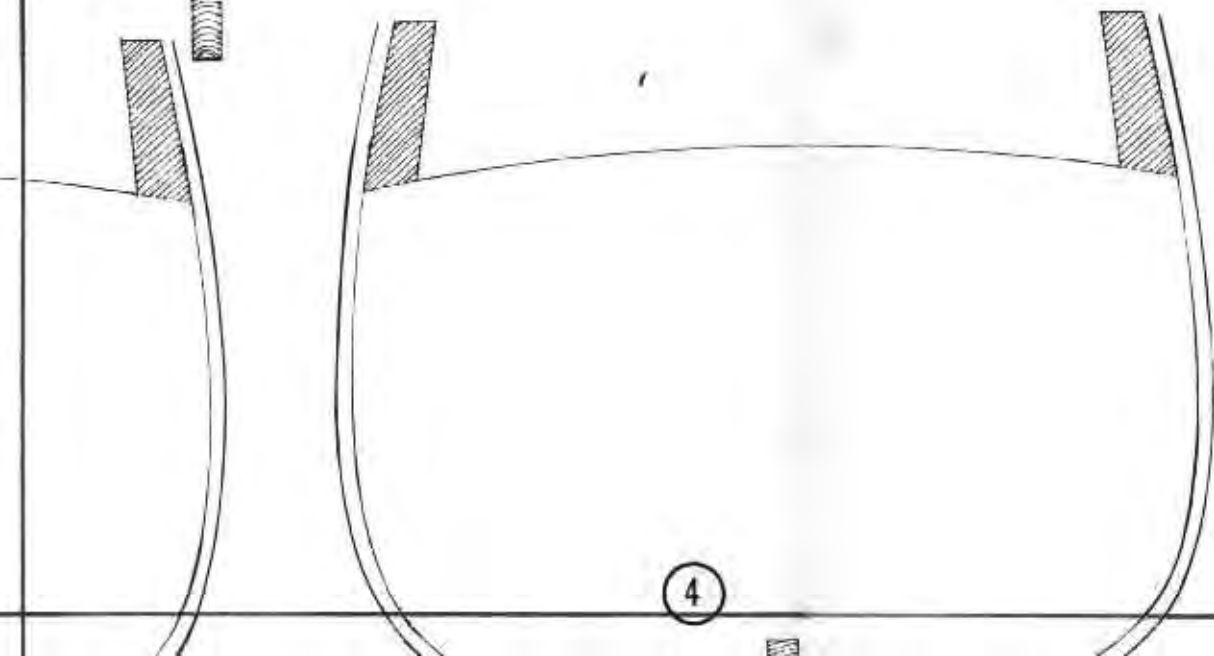
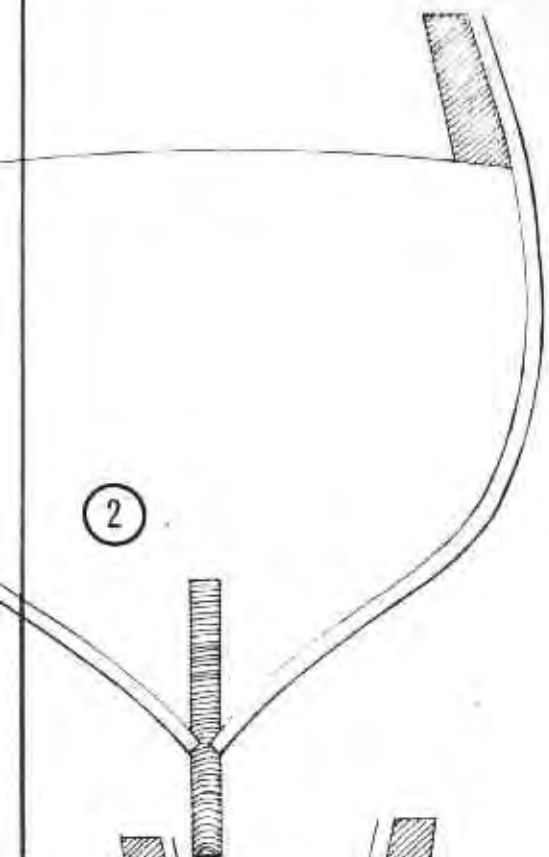

All the frames have to be made of plywood, 4 mm thick.

Tous les membres doivent être faits de contre plaque de 4 mm.

6

ATTENZIONE! LA PARTE TRATTEGGIATA DELLE ORDINATE DEVE ESSERE ASPORTATA DOPO AVER APPLICATO IL FASCIALE.

ACHTUNG! DIE SCHRÄFFIERTEN TEILE DER SPANTEN MÜSSEN ENTFERNT (BESSER HERAUSGESCHNITTEN) WERDEN.

ATTENTION, PLEASE! The hatched parts of the frames must be removed.

ATTENTION! Les parties hachées des membres doivent être écartées.

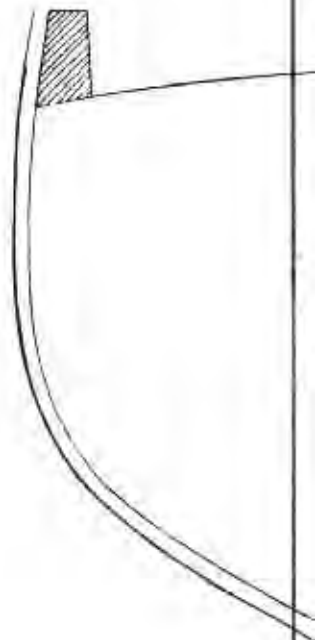

PRIMA DI INCASTRARLE NELLE RISPETTIVE TACCHE DELLA
VERSO PRUA ALLE ORDINATE DA 1 A 5, E GLI SPINGOLI VE
CONSENTIRE UNA PERFETTA ADESIONE DEL FASCIALE.

PRIMA DI INCASTRARLE NELLE RISPETTIVE TACCHE DELLA

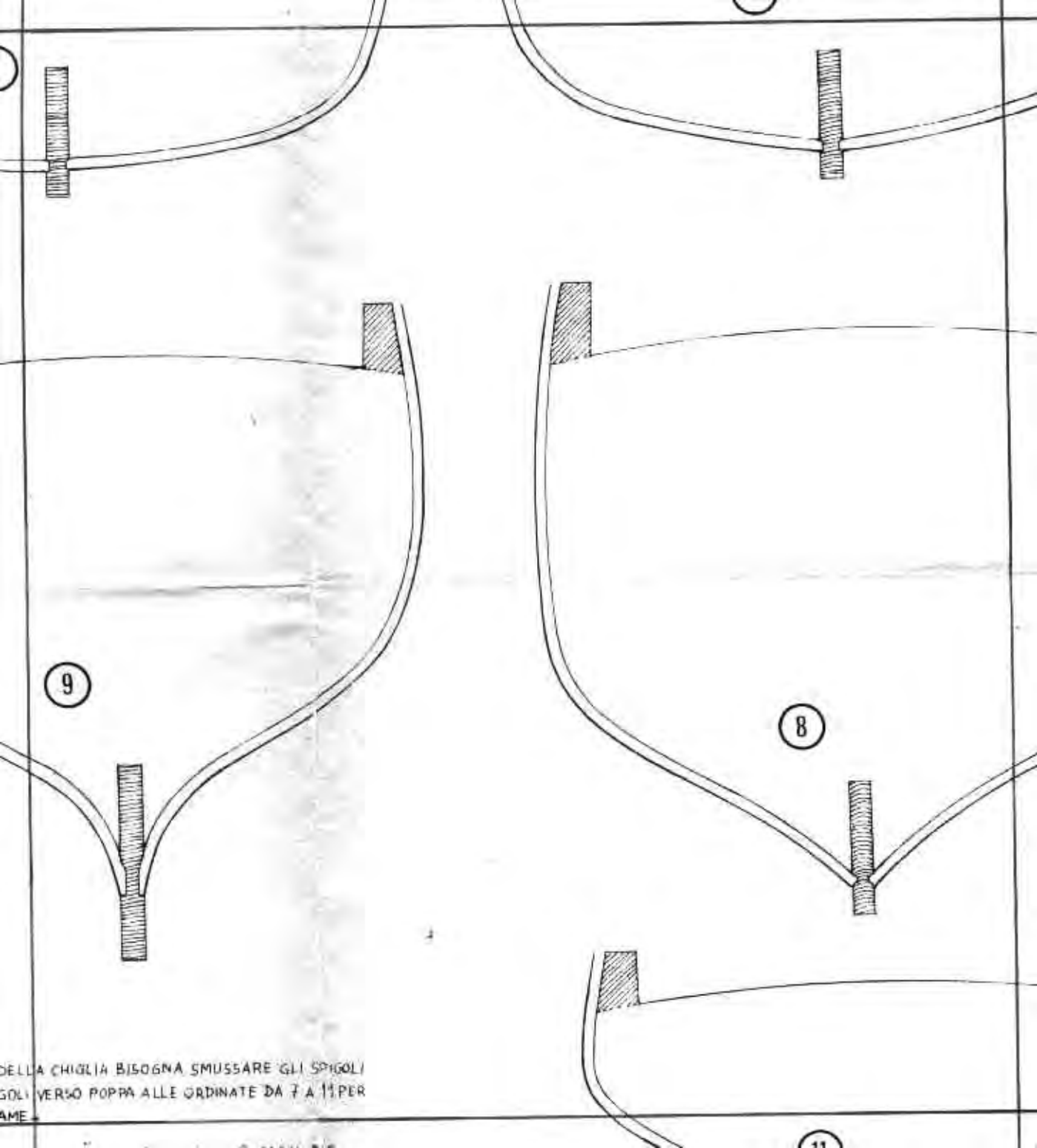

9

8

11

DELLA CHIGLIA BISOGNA SMUSSARE GLI SPIGOLI
GLI SPIGOLI VERSO POPPA ALLE ORDINATE DA 7 A 11 PER
L'ESEMPLO

4

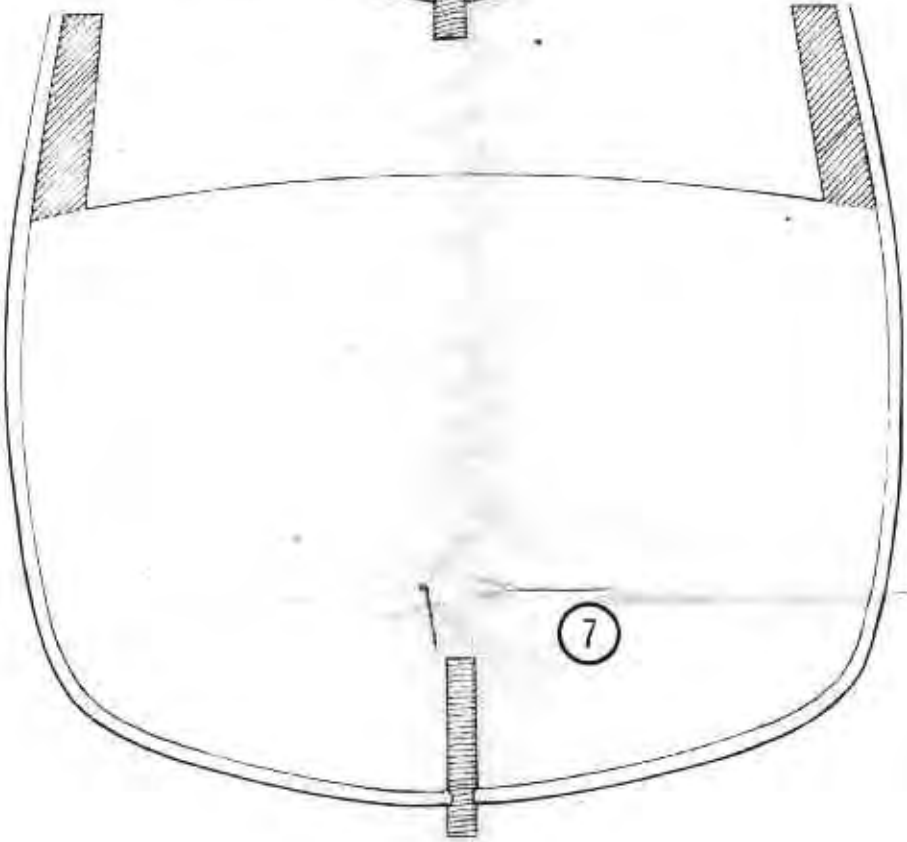

7

BEVOR DIE WANTEN IN DIE EINSCHNITTE AM KIEL EINGEMARTHAISERT WERDEN MÜSSEN DIE RÄNDER DER WANTEN 1-2-3-4 UND 5 NACH VORN (11) NACH DEM BUG ZU ABGESCHRÄGT WERDEN.

Before the frames are mortised into the notches of the keel, frames 1-2-3-4 and 5 have to be bevelled towards the bow (11) towards the stern, in order to adapt them to the keel.

Avant d'emmarquiser les membres dans les entailles de la quille, les bords des membres 1-2-3-4 et 5 vers l'avant (11) vers l'arrière doivent être chanfreinés.

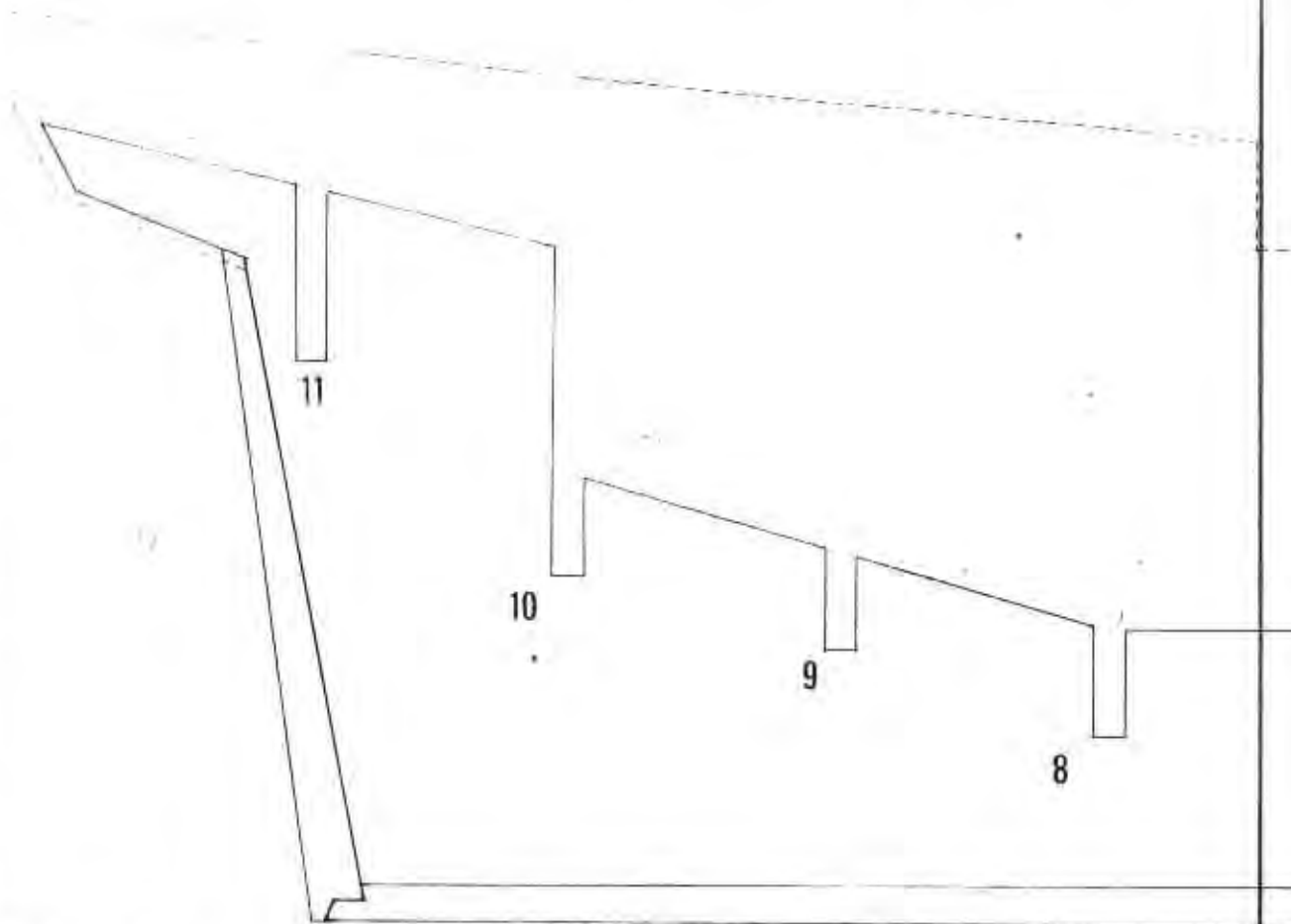

EINGEFÜGT WERDEN, MUß MAN DIE
NACH DEM HECK ZU, DIE DER WANTEN

es of the keel, the edges of the frames
towards the bow, and those of the
to adhere perfectly to the planking.

ies de la quille, il faudra écorner les
vant, et celles des membres 7/11 vers la poupe.

11



7

6

5

